

ITB/ITCB/HV, ICB/Twin



PROGRAMMING MANUAL

For Technical Service, contact Bunn-O-Matic Corporation at 1-800-286-6070.

Bunn-O-Matic Corporation
Post Office Box 3227, Springfield, Illinois 62708-3227
Phone (217) 529-6601 | Fax (217) 529-6644

BUNN-O-MATIC COMMERCIAL PRODUCT WARRANTY

Bunn-O-Matic Corp. ("BUNN") warrants equipment manufactured by it as follows:

- 1) Airpots, thermal carafes, decanters, GPR servers, iced tea/coffee dispensers, MCR/MCP/MCA single cup brewers, thermal servers and ThermoFresh® servers (mechanical and digital) 1 year parts and 1 year labor.
- 2) All other equipment - 2 years parts and 1 year labor plus added warranties as specified below:
 - a) Electronic circuit and/or control boards - parts and labor for 3 years.
 - b) Compressors on refrigeration equipment - 5 years parts and 1 year labor.
 - c) Grinding burrs on coffee grinding equipment for 4 years or 40,000 pounds of coffee, whichever comes first.

These warranty periods run from the date of installation BUNN warrants that the equipment manufactured by it will be commercially free of defects in material and workmanship existing at the time of manufacture and appearing within the applicable warranty period. This warranty does not apply to any equipment, component or part that was not manufactured by BUNN or that, in BUNN's judgment, has been affected by misuse, neglect, alteration, improper installation or operation, improper maintenance or repair, non periodic cleaning and descaling, equipment failures related to poor water quality, damage or casualty. In addition, the warranty does not apply to replacement of items subject to normal use including but not limited to user replaceable parts such as seals and gaskets. This warranty is conditioned on the Buyer 1) giving BUNN prompt notice of any claim to be made under this warranty by telephone at (217) 529-6601 or by writing to Post Office Box 3227, Springfield, Illinois 62708-3227; 2) if requested by BUNN, shipping the defective equipment prepaid to an authorized BUNN service location; and 3) receiving prior authorization from BUNN that the defective equipment is under warranty.

THE FOREGOING WARRANTY IS EXCLUSIVE AND IS IN LIEU OF ANY OTHER WARRANTY, WRITTEN OR ORAL, EXPRESS OR IMPLIED, INCLUDING, BUT NOT LIMITED TO, ANY IMPLIED WARRANTY OF EITHER MERCHANTABILITY OR FITNESS FOR A PARTICULAR PURPOSE. The agents, dealers or employees of BUNN are not authorized to make modifications to this warranty or to make additional warranties that are binding on BUNN. Accordingly, statements by such individuals, whether oral or written, do not constitute warranties and should not be relied upon.

If BUNN determines in its sole discretion that the equipment does not conform to the warranty, BUNN, at its exclusive option while the equipment is under warranty, shall either 1) provide at no charge replacement parts and/or labor (during the applicable parts and labor warranty periods specified above) to repair the defective components, provided that this repair is done by a BUNN Authorized Service Representative; or 2) shall replace the equipment or refund the purchase price for the equipment.

THE BUYER'S REMEDY AGAINST BUNN FOR THE BREACH OF ANY OBLIGATION ARISING OUT OF THE SALE OF THIS EQUIPMENT, WHETHER DERIVED FROM WARRANTY OR OTHERWISE, SHALL BE LIMITED, AT BUNN'S SOLE OPTION AS SPECIFIED HEREIN, TO REPAIR, REPLACEMENT OR REFUND.

In no event shall BUNN be liable for any other damage or loss, including, but not limited to, lost profits, lost sales, loss of use of equipment, claims of Buyer's customers, cost of capital, cost of down time, cost of substitute equipment, facilities or services, or any other special, incidental or consequential damages.

392, A Partner You Can Count On, Air Infusion, AutoPOD, AXIOM, BrewLOGIC, BrewMETER, Brew Better Not Bitter, BrewWISE, BrewWIZARD, BUNN Espresso, BUNN Family Gourmet, BUNN Gourmet, BUNN Pour-O-Matic, BUNN, BUNN with the stylized red line, BUNNlink, Bunn-OMatic, Bunn-O-Matic, BUNNserve, BUNNSERVE with the stylized wrench design, Cool Froth, DBC, Dr. Brew stylized Dr. design, Dual, Easy Pour, EasyClear, EasyGard, FlavorGard, Gourmet Ice, Gourmet Juice, High Intensity, iMIX, Infusion Series, Intellisteam, My Café, Phase Brew, PowerLogic, Quality Beverage Equipment Worldwide, Respect Earth, Respect Earth with the stylized leaf and coffee cherry design, Safety-Fresh, savemycoffee.com, Scale-Pro, Silver Series, Single, Smart Funnel, Smart Hopper, SmartWAVE, Soft Heat, SplashGard, The Mark of Quality in Beverage Equipment Worldwide, ThermoFresh, Titan, trifecta, TRIFECTA (stylized logo), Velocity Brew, Air Brew, Beverage Bar Creator, Beverage Profit Calculator, Brew better, not bitter., Build-A-Drink, BUNNSource, Coffee At Its Best, Cyclonic Heating System, Daypart, Digital Brewer Control, Element, Milk Texturing Fusion, Nothing Brews Like a BUNN, Picture Prompted Cleaning, Pouring Profits, Signature Series, Sure Tamp, Tea At Its Best, The Horizontal Red Line, Ultra are either trademarks or registered trademarks of Bunn-O-Matic Corporation. The commercial trifecta® brewer housing configuration is a trademark of Bunn-O-Matic Corporation.

INTRODUCTION

ITB

This equipment will brew tea into an awaiting dispenser or reservoir. It is only for indoor use on a sturdy counter or shelf.

The ITB uses recipe settings to brew tea. It has an LCD for digital readout and programming. The user is able to select regular or quick brew for tea programming. Other features include Pre-Infusion and Pulse Brew, quick and standard brew, Energy Savings mode, BUNNLink compatible, Freshness Timer, Sanitation Alert, and brew counters. Available in low profile, dual dilution and sweetener models.

ITCB

This equipment will brew either tea or coffee into an awaiting dispenser or reservoir. It can be easily configured for 120V 15 amp, 120/208V 20 amp or 120/240V 20 amp. The brewer may have an auxiliary hot water faucet. It is only for indoor use on a sturdy counter or shelf.

The Infusion Series combines BrewWISE, CDBC and Tea Brewers into one. ITCB is able to brew both tea and coffee with recipe settings. It has an LCD for digital readout and programming along with the Smart Funnel options for coffee. The user is able to select regular or quick brew for tea programming. Other features include: Pre-Infusion, Pulse Brew, quick and standard brew, and BrewWISE, Energy Savings mode, BUNNLink compatible, Smart Reader compatible, Freshness Timer, Sanitation Alert, and sweetener with low product detection.

CONTENTS

Warranty	2
Introduction	3
Programming Flow Chart-ICB	4
Programming Flow Chart-ICB Twin	5
Programming Flow Chart-ITB	6
Programming Flow Chart-ITCB	7
Programming Flow Chart-ITCB-DV HV	8
Programming Flow Chart-ITCB HV TWIN.....	9
Factory Defaults	10
Programming With Recipe Card	11
Programming With Ad Card	12
Programming.....	13
Troubleshooting	31

PROGRAMMING FUNCTIONS - FLOW CHART

PROGRAMMING FUNCTIONS - LEVEL 1

BREW LOCKOUT?
NO DONE YES

Digital Brewer Control™

PROGRAMMING FUNCTIONS - LEVEL 2

SET LANGUAGE?
NO YES

Digital Brewer Control™

UNITS
METRIC DONE ENG

Digital Brewer Control™

REVIEW RECIPES
NO YES

Digital Brewer Control™

ASSIGN RECIPE
NO YES

Digital Brewer Control™

SET NEW RECIPE?
NO YES

Digital Brewer Control™

SET TEMP 200°
(-) DONE (+)

Digital Brewer Control™

READY DEGREE 5°
(-) DONE (+)

Digital Brewer Control™

ENABLE ADS?
NO DONE YES

Digital Brewer Control™

ENABLE SANITATION
NO DONE YES

Digital Brewer Control™

ENABL ENERGYSAVR
NO DONE YES

Digital Brewer Control™

ENABLE FRESH TIMER
NO DONE YES

Digital Brewer Control™

XX REFILL XXX
(-) DONE (+)

Digital Brewer Control™

SPRAY OZ/M: XX.X
(-) DONE (+)

Digital Brewer Control™

BYPASS OZ/M: XX.X
(-) DONE (+)

Digital Brewer Control™

CALIBRATE FLOW?
NO YES

Digital Brewer Control™

BREW COUNTERS?
NO YES

Digital Brewer Control™

ENTER ASSET #
NO YES

Digital Brewer Control™

ENTER SERVICE #
NO YES

Digital Brewer Control™

SERVICE TOOLS
NO YES

Digital Brewer Control™

FACTORY DEFAULTS
NO YES

Digital Brewer Control™

PROGRAMMING FUNCTIONS - FLOW CHART

PROGRAMMING FUNCTIONS - LEVEL 1

BREW LOCKOUT?
NO DONE YES

Digital Brewer Control™

PROGRAMMING FUNCTIONS - LEVEL 2

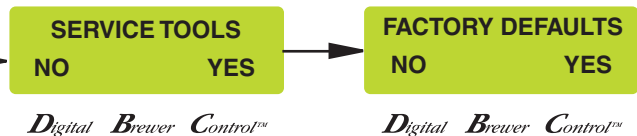
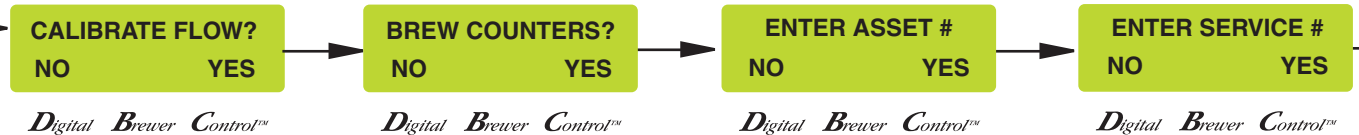
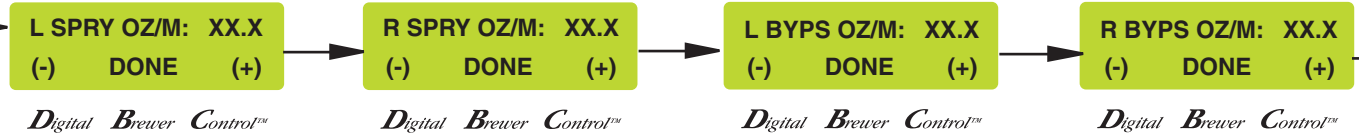
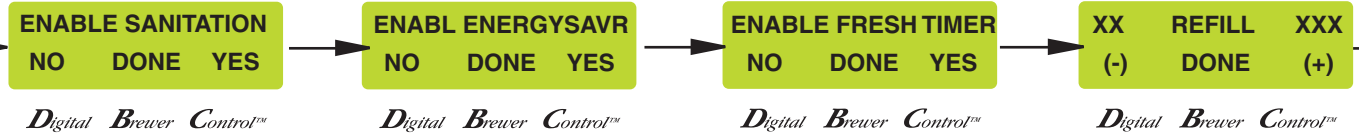
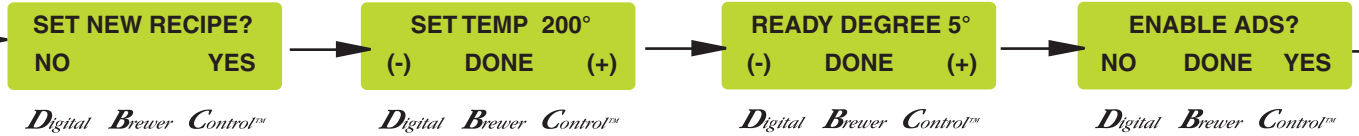

PROGRAMMING FUNCTIONS - FLOW CHART

PROGRAMMING FUNCTIONS - LEVEL 1

BREW LOCKOUT?
NO DONE YES

Digital Brewer Control™

PROGRAMMING FUNCTIONS - LEVEL 2

SET LANGUAGE?
NO YES

Digital Brewer Control™

UNITS
METRIC DONE ENG

Digital Brewer Control™

REVIEW RECIPES
NO YES

Digital Brewer Control™

ASSIGN RECIPE
NO YES

Digital Brewer Control™

MASTER TEMP 205°
(-) DONE (+)

Digital Brewer Control™

READY DEGREE 5°
(-) DONE (+)

Digital Brewer Control™

ENABLE ADS?
NO DONE YES

Digital Brewer Control™

ENABLE SANITATION
NO DONE YES

Digital Brewer Control™

ENABL ENERGYSAVR
NO DONE YES

Digital Brewer Control™

ENABLE FRESH TIMER
NO DONE YES

Digital Brewer Control™

XX REFILL XXX
(-) DONE (+)

Digital Brewer Control™

SPRAY OZ/M: XX.X
(-) DONE (+)

Digital Brewer Control™

DILUTE OZ/M: XX.X
(-) DONE (+)

Digital Brewer Control™

CALIBRATE FLOW?
NO YES

Digital Brewer Control™

BREW COUNTERS?
NO YES

Digital Brewer Control™

ENTER ASSET #
NO YES

Digital Brewer Control™

ENTER SERVICE #
NO YES

Digital Brewer Control™

SERVICE TOOLS
NO YES

Digital Brewer Control™

FACTORY DEFAULTS
NO YES

Digital Brewer Control™

PROGRAMMING FUNCTIONS - FLOW CHART

PROGRAMMING FUNCTIONS - LEVEL 1

BREW LOCKOUT?
NO DONE YES

Digital Brewer Control™

PROGRAMMING FUNCTIONS - LEVEL 2

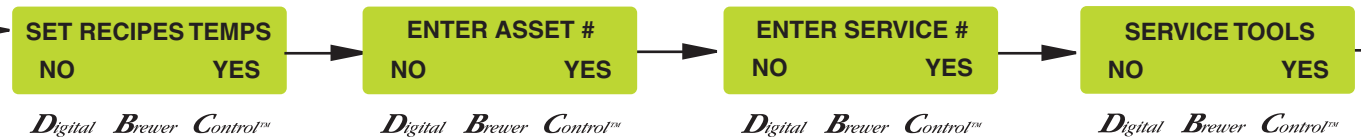
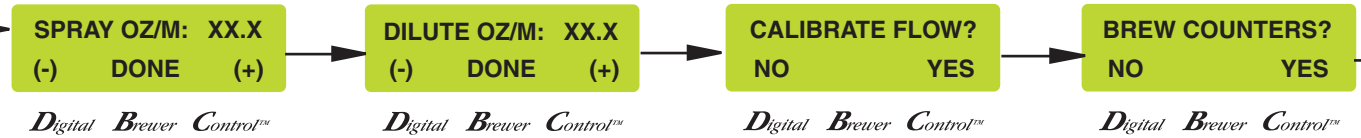
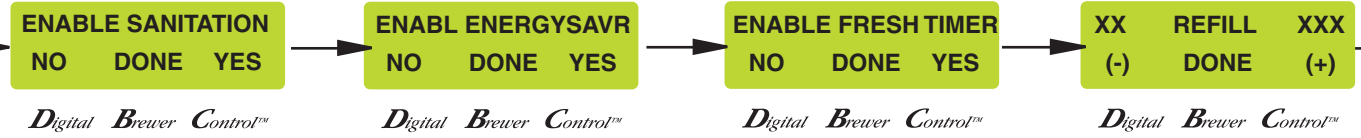
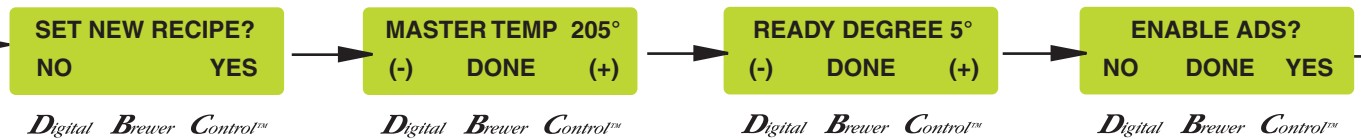
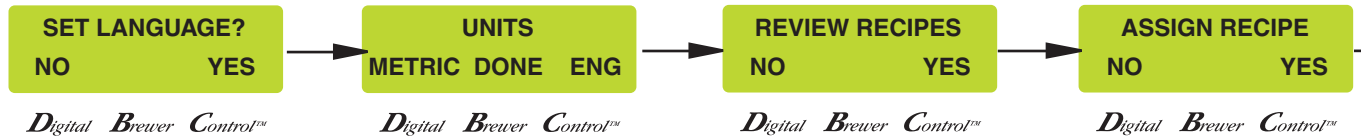

PROGRAMMING FUNCTIONS - FLOW CHART

PROGRAMMING FUNCTIONS - LEVEL 1

BREW LOCKOUT ?
NO DONE YES

Digital Brewer Control™

PROGRAMMING FUNCTIONS - LEVEL 2



FACTORY DEFAULTS

	ICB	ICB TWIN	ITCB	ITB	ITCB HV	HV TWIN
Brew Lockout	Enabled	Enabled	Disabled	Disabled	Enabled	Enabled
Set Language	English	English	English	English	English	English
Units	English	English	English	English	English	English
Review Recipes	✓	✓	✓	✓	✓	✓
Assign Recipes	✓	✓	✓	✓	✓	✓
Set New Recipe	✓	✓	✓	X	✓	✓
Set (Master) Temp	200°	200°	205°	205°	200°	200°
Ready Degree	5°	5°	5°	5°	5°	5°
Enable Ads	Disabled	Disabled	Disabled	Disabled	Disabled	Disabled
Enable Sanitation	Disabled	Disabled	Disabled	Disabled	Disabled	Disabled
Enable Energy Saver	Disabled	Disabled	Disabled	Disabled	Disabled	Disabled
Enable Fresh Timer	Disabled	Disabled	Disabled	Disabled	Disabled	Disabled
Refill	155	155	155	155	155	155
Left Spray Oz.	X	35.0	X	X	X	
Right Spray Oz.	X	35.5	X	X	X	
Spray Oz.	36.0	X	24.0	24.0	36.0	
Left Bypass Oz.	X	30.0	X	X	X	
Right Bypass Oz.	X	35.5	X	X	X	
Bypass	31.0	X	X	X	31.0	
Dilution Oz.	X	X	71.0	71.0	71.0	
Calibrate Flow	Reset	Reset	Reset	Reset	Reset	Reset
Set Recipes Temps	X	X	Coffee 200° Tea 205°	X	X	X
Brew Alert	N/A	N/A	N/A	N/A	Disabled	Disabled

PROGRAMMING WITH RECIPE CARD

NOT AVAILABLE ON ITB

Using a RECIPE CARD to load recipes:

The **RECIPE CARD** includes all the information needed to set up that particular coffee/tea name. The information from the **RECIPE CARD** is loaded into the brewer's memory by holding the chip area up to the brewer's **SENSING COIL**. This information can include all the recipe settings for that particular name. These can all be loaded in seconds.

NOTE: Instructions to program the brewer and grinder are printed on the **RECIPE CARD**, along with the coffee name that is being programmed.

Procedure to program the coffee name:

1. Remove the funnel(s) if present.
2. Position the **RECIPE CARD** vertically, so that the top end of the **CHIP** is beneath the (Left on Twins) **SENSING COIL** (located on the underneath side of the front display panel).
3. After a short pause the display will read **CARD CONTAINS RECIPE FOR** then will change to **(RECIPE NAME) SHOW-QUIT-SAVE**. All brewing parameters for that recipe are now transferred from the **CARD** to the brewer.
4. To show (view) this information, press and release **SHOW**. The display will scroll through all of the brew settings for that recipe. This display will then return to **CARD CONTAINS RECIPE FOR** then will change to **(RECIPE NAME) SHOW-QUIT-SAVE**.
5. If all brew settings are correct, press **SAVE**. The display will read **(RECIPE NAME) SETUP COMPLETE**. All brew settings for that name are now stored in the brewer's memory.
6. If the brewing information is not correct, or it is desired to exit the setup before the settings are loaded into the brewer's memory, press **QUIT**. The display will read **(RECIPE NAME) NOT SAVED**. The display will then return to the **MAIN SCREEN**.

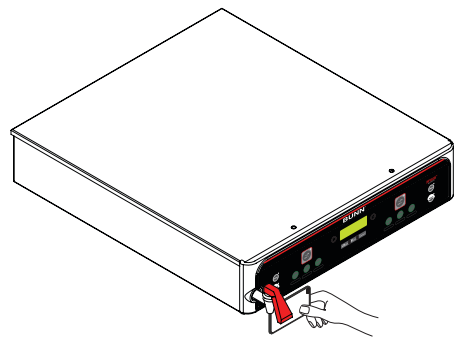
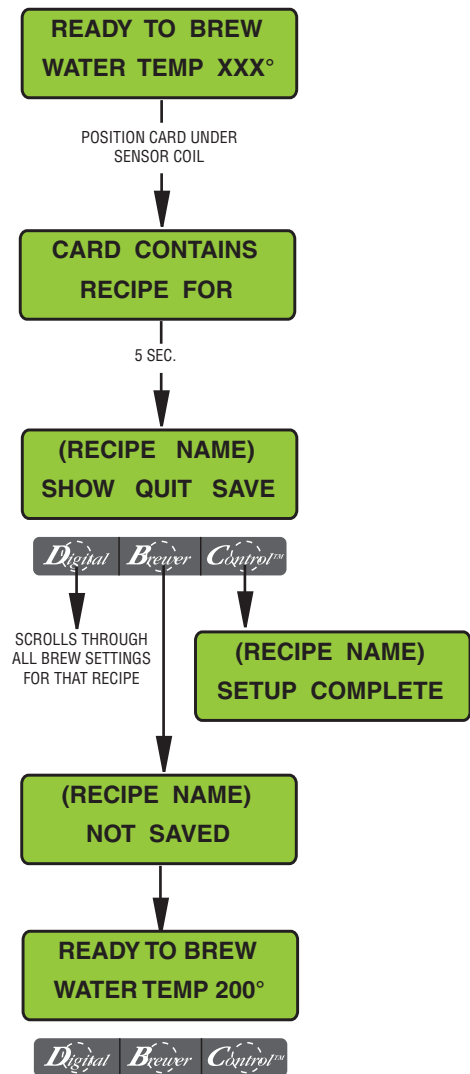

PROGRAMMING WITH AD CARD

NOT AVAILABLE ON ITB

Using an AD CARD to load ADS:

The information is loaded into the brewer's memory by holding the chip area up to the brewer's **SENSING COIL**.

NOTE: Instructions to program the brewer are printed on the **AD CARD**.

Procedure to program the AD:

1. Remove the funnel(s) if present.
2. Position the **RECIPE CARD** vertically, so that the top end of the **CHIP** is beneath the (Left on Twins) **SENSING COIL** (located on the underneath side of the front display panel).
3. After a short pause the display will read **CARD CONTAIN ADS/SHOW-QUIT-SAVE**.
4. To show (view) this information, select **"SHOW"**. The display will scroll through all of the ad on that chip. The display will then return to **CARD CONTAIN ADS/SHOW-QUIT-SAVE**.
5. If message is correct, press **SAVE**. The display will read **AD MESSAGE SETUP COMPLETE**. The ad is now stored in the brewer's memory.
6. If the ad is not correct, or it is desired to exit the setup before the ad is loaded into the brewer's memory, press **QUIT**. The display will then return to the **MAIN SCREEN**.

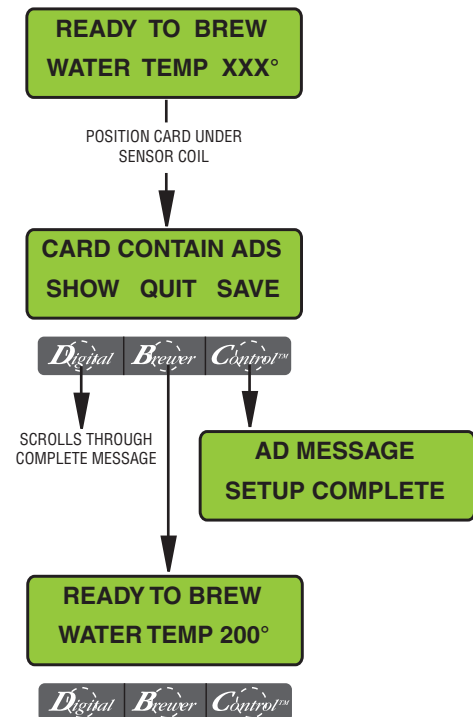
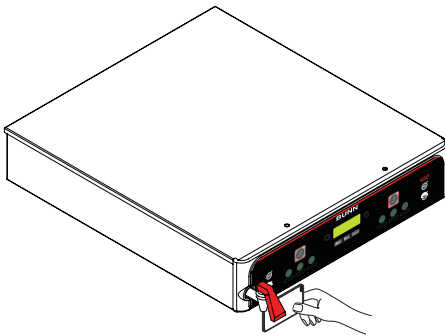

NOTE: ENABLE ADS must be turned on in **LEVEL 2** in order for the newly programmed ad message to be displayed.

PROGRAMMING THE BREWER

PROGRAMMING FUNCTIONS - LEVEL 1

* BREW LOCKOUT

This function allows the operator to prevent or allow brewing if the water temperature is less than the set **READY** temperature.

Procedure for setting Brew Lockout:

1. To access this function screen press and hold the right hidden button. Release when the display reads:

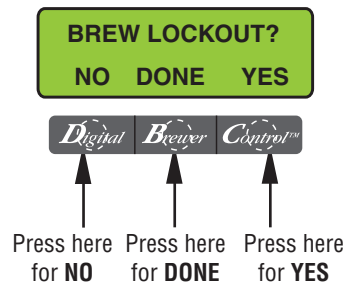

2. The **YES** or **NO** should be flashing. Select **YES** to prevent brewing if the water temperature is below the set **READY** temperature. Select **NO** to permit brewing at any water temperature.
3. When finished, select **DONE**. This will exit this function screen and return to the **MAIN SCREEN**.

PROGRAMMING FUNCTIONS - LEVEL 2

The functions in the second level of programming allow the operator to adjust brew settings and other feature options.

To access the level 2 function screens press and hold the right hidden button for approximately 5 seconds. Release when the display reads:

* SET LANGUAGE

This function allows the operator to select the language used for the display.

Procedure for setting Language:

1. Press and hold the right hidden button until the display reads **SET LANGUAGE?** and release.
2. Press **YES** to proceed. The display should now read **ENGLISH**. Using (-) and (+), scroll through the available languages until the desired language is shown on the display.
3. When finished, press **SELECT**. If the language selected is different from the current settings, the display will read **CHANGE LANGUAGE? ARE YOU SURE?** and then will change to **CHANGE LANGUAGE?** To convert the display to the new language, select **YES**. To retain the current language, select **NO**.
4. The display should now read **UNITS**. To exit programming and return to the **MAIN SCREEN**, press **ENABLE BREW ON/OFF** switch.

(cont.)

PROGRAMMING THE BREWER (cont.)

PROGRAMMING FUNCTIONS - LEVEL 2 (cont.)

* UNITS

This function allows the operator to select if numeric settings are displayed in English or Metric units.

Procedure for setting the Units:

1. Press and hold the right hidden button until the display reads **SET LANGUAGE?** Press and release the right hidden button until the display reads **UNITS**. The **METRIC** or **ENG** should be flashing.
2. Select **METRIC** to have settings displayed in Metric units. Select **ENG** for English units.

NOTE: Changing the **UNIT** settings will restore ALL settings to Factory Default.

3. Select **DONE** to advance to the next programming screen. To exit programming and return to the Main Screen, press **ENABLE BREW ON/OFF** switch.

NOTE: This manual is written based on Factory Default Settings (English Units). If brewer is set for Metric Units, displays will be different (ex: Brew oz will become Brew liters, Temperature changes from F° to C°).

ADJUSTMENT RANGES			
	ICB	ITB/ITCB	HV
BREW OZ	OFF/10-224	OFF/10-135	
% BYPASS	0-90%		0-90%
DILUTE OZ		0-580	
DILUTE DELAY		0-10 Min	
PULSE BREW	1st On Time – OFF to 1 Min		
	Off Time – OFF - 20 seconds		
	Last On Time – Pre-Infuse to 1 Min		
DRIP TIME	OFF to 5 Min		
SWEET METER		1-14	

DEFAULT RECIPE CHART - ICB	
No Name Coffee	Jamaica Blue Mtn
Regular	Guatemalan
Decaf	Light Roast
Colombian	Dark Roast
Colombia Supremo	Espresso
Costa Rican	Amaretto
Ethiopian	Hazelnut
Kona	French Vanilla
Kenya AA	Irish Creme
Sumatran	Vanilla Nut
French Roast	Caramel
Italian Roast	Raspberry
Mocha Java	Almond
House Blend	Dark Mtn Roast
Breakfast Blend	Hot Tea

* REVIEW RECIPES (Modify or Show recipes)

This function has two parts:

1. It allows the operator to view the brew settings for the various coffee recipes stored into the brewer.
2. It allows the operator to modify (change) any of the brew settings for a particular recipe stored in the brewer.

Procedure for reviewing the recipes:

1. Press and hold the right hidden switch until the display reads **SET LANGUAGE**. Press and release the right hidden switch until the display reads **REVIEW RECIPES**. Select **YES**.
2. The display should now read the name of the first recipe, along with **MODIFY SHOW** and **NEXT**.

DEFAULT RECIPE CHART - ITB/ITCB	
Tea 1	Iced Coffee (ITCB ONLY)
Tea 2	No Name Coffee (ITCB ONLY)
Tea 3	
Hot Tea	

DEFAULT ASSIGNMENTS			
	BREW A	BREW B	BREW C
ICB	Regular	Decaf	Brkfst Blnd
ITB	Disabled	Tea 1	Disabled
ITCB	Tea 1	Hot Tea	NoNameCoff
HV	Regular	Decaf	Ice Tea

(cont.)

PROGRAMMING THE BREWER (cont.)

PROGRAMMING FUNCTIONS - LEVEL 2 (cont.)

3. Select **SHOW**. The screen will scroll through all the brew settings for that particular recipe. When finished, the display will return to the recipe name just viewed.
4. To see the settings again, select **SHOW**. To change settings, select **MODIFY**. Then the screen will display **BREW OZ** and a batch light will be blinking.
5. Using (-) or (+), set the amount of brew water to be dispensed for that batch size.
6. When finished, press the other batch size and repeat step #8.
7. When finished setting both batch sizes, select **DONE**. The display should read **2 BATCHES DONE?**
8. If both batch sizes are not correct press and release NO to return to the **BREW OZ** setup screen and repeat steps #8, 9 and 10.

VIEW/MODIFY ITEMS		
ICB	ITB/ITCB	ITCB-DV HV/TWIN
Brew Ounces		
% Bypass	Dilution Ounces	Both
	Dilution Delay Time	
Pulse Brew/Preinfusion Times		
Drip Times		
* SWEET METER		

* ITB/ITCB/ITCB-DV/TWIN HV WITH FACTORY SWEETENER

BY PRESSING "MODIFY", YOU CAN STEP THROUGH & CHANGE ALL THE BREW SETTINGS FOR THAT RECIPE, SIMPLY FOLLOW THE ON SCREEN PROMPTS

BY PRESSING "SHOW", THE DISPLAY WILL AUTOMATICALLY SCROLL THROUGH ALL THE BREW SETTINGS FOR THAT RECIPE

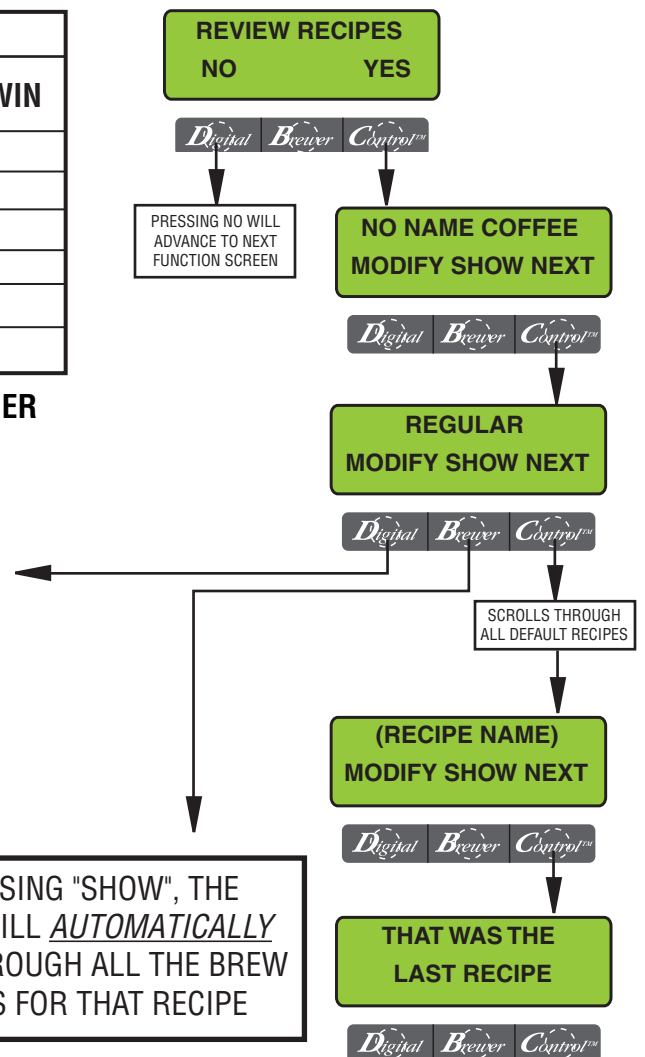

PROGRAMMING FUNCTIONS - LEVEL 2 (cont.)

9. If both batch sizes are correct, press **YES**. This will advance to the **DILUTE OZ** (ITCB/HV) or **BYPASS %** (ICB/ITCB HV)
10. Using (-) or (+), set the amount of dilution water for that particular batch size to be dispensed through the dilution nozzle into the tea dispenser (ITCB/HV) or % bypass water to be dispensed around the filter/grounds (ICB/ITCB HV).
11. When finished, press the other batch size and repeat step #10.
12. When finished setting both batch sizes, press and release **DONE**. The display should read **2 BATCHES DONE?**
13. If both batch sizes are not correct, select **NO** to return to the **BYPASS %** function (ICB) or **DILUTE OZ** function (ITCB/HV) and repeat steps #10-12.
14. If both batch sizes are correct, press **YES**. This will advance to the **DILUTE DELY** function (ITCB/HV) or **SET PULSE BREW** function (ICB/HV) jump to step # 21.
15. **(ITB/ITCB/HV ONLY)** Press and release **YES**. The display should now read **DILUTE DELY:** and a batch light will be blinking. Press and release the batch size to be modified.
16. Using (-) or (+), set the time delay for the dilution water to start for that particular batch size.
17. When finished, press the other batch size and repeat step # 16.
18. When finished setting both batch sizes, press and release **DONE**. The display should read **2 BATCHES DONE?**
19. If both batch sizes are not correct, press and release **NO** to return to the **DILUTE DELY** setup screen and repeat steps 16 - 18.
20. If both batch sizes are correct, press **YES**. The display should now read **SET PULSE BREW**.
21. To set **PULSE BREW** press **YES**. The display should now read **SELECT METHOD**. To set the **EASY** method, continue to step # 22. To set by **MANUAL** method, jump to step # 28.

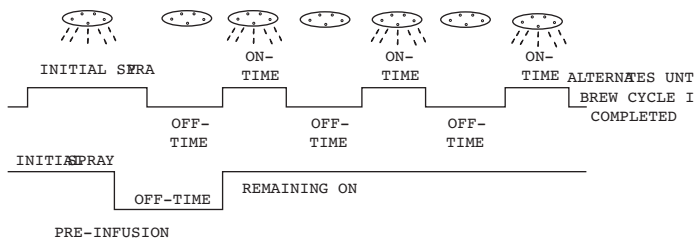

Setting Pulse Brew – EASY Pulse Brew

Range: Minimum: will adjust to the minimum time required to brew that batch using the set brew volumes and flow rate for the sprayhead. Maximum – will adjust depending on settings and will always be minimum time + 3 minutes. The brewer will automatically calculate what the 1ST ON TIME, OFF TIMES, and LAST ON TIME will be using THE INITIAL ON TIME, plus a 7 pulse routine.

22. Select **EASY**. With **EASY** flashing, select **NEXT**.
23. The display should now read **BREW TIME:** and a batch light will be blinking. Select the batch size to be modified.
24. Using (-) or (+), set the total brew time desired including spray times and off times.
25. When finished, press the other batch size and repeat step # 24.
26. When finished setting both batch sizes, press **DONE**. The display will show the pulse settings to accommodate the brew time entered. Press and release each batch size to display the settings for that batch. After a delay, the display should read **2 BATCHES DONE?**
27. If both batch sizes are not correct, press **NO** to return to the **BREW TIME** setup screen and repeat steps 24-26.

Setting Pulse Brew/PreInfusion – MANUAL

28. Select **MANUAL**. With **MANUAL** flashing, select **NEXT**.
29. The display should now read, **1ST ON TIME** and a batch light will be blinking. Select the batch size to be modified.
30. Using (-) or (+), adjust the **1ST ON TIME**.
31. When finished, press the other batch size and repeat step # 30.
- NOTE:** To disable pulse brew, set 1ST ON TIME to OFF. Brewer will automatically pulse on tea recipes with a brew volume greater than 86.0 oz.
32. When finished setting both batch sizes, press **DONE**.
33. The display should now read **OFF TIME**. Adjust the **OFF TIME** using (-) or (+).
34. When finished, press the other batch size and repeat step # 33.

(cont.)

PROGRAMMING FUNCTIONS - LEVEL 2 (cont.)

35. When finished setting both batch sizes, press and release **DONE**.
36. The display should now read **LAST ON:**. Adjust the **LAST ON TIME** using (-) or (+). If **PREINFUSION** is desired, set the **LAST ON TIME** to **Prel**.
37. When finished, press the other batch size and repeat step # 36.
38. When finished setting both batch sizes, press and release **DONE**.
39. The display will show the three times just entered. Press and release each batch size to display the settings for that batch. If the **1ST ON TIME** is set to **OFF**, the display will read **PULSE BREW DISABLED**. After a 5 second delay, the display will read **2 BATCHES DONE?**
40. If both the pulse brew settings for both batch sizes are not correct, press and release **NO** to return to the **1ST ON TIME** setup screen and repeat steps 24 through 39.
41. If both batch sizes are correct, press **YES**. The display should now read **DRIP TIME**.

Setting DRIP TIME:

NOTE: Drip time also controls the solenoid on time for models with optional funnel locks.

42. The display should now read **DRIP TIME**, along with either the word **OFF** or a time showing. A batch light will also be blinking.
43. Using (-) or (+), set the amount of time from when the brew spray ends to when the funnel is emptied of hot liquid.
44. When finished, press the other batch size and repeat step #43.
45. When finished setting both batch sizes, press and release **DONE**. The display should read **2 BATCHES DONE?**
46. Select **YES**. The screen should show the name of the recipe being programmed (modified) along with **SETUP COMPLETE (except for ITCB w/Sweet meter, step # 47)**.

Setting SWEET METER: Optional on ITCB

This function allows the operator to adjust the amount

of sweetener added to the dilution water. The solenoid is pulsed on/off for the duration of the dilution cycle. Setting #1 will produce the least amount of sweetener (weakest) and (#14) being the most (strongest).

Procedure:

47. The display should now read "**SWEETNER**"
48. Press (-) to decrease the amount, or (+) to increase. (Range: 1 - 14)
49. When finished, press and release the right hidden switch, or press and release the "**ENABLE BREW ON/OFF**" switch to return to the main screen.

PROGRAMMING FUNCTIONS - LEVEL 2 (cont.)

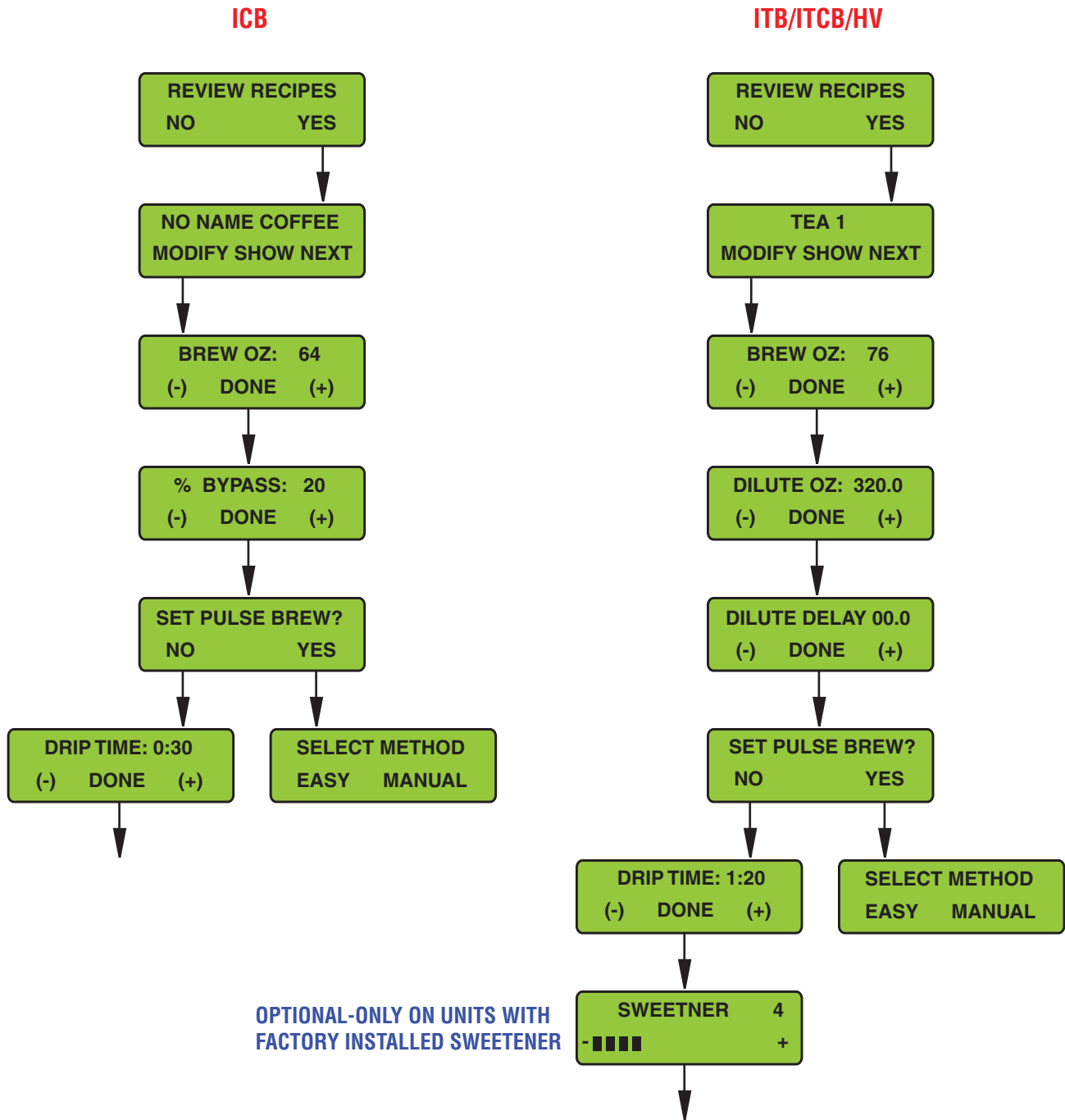

OVERVIEW ONLY - SOME SCREENS OMITTED

PROGRAMMING THE BREWER (cont.)

PROGRAMMING FUNCTIONS - LEVEL 2 (cont.)

* ASSIGN RECIPE to or disable BREW SWITCH(S)

This function allows the operator to assign a recipe to (or disable) each of the 3 brew switches (A, B, C). Any saved recipes listed under "REVIEW RECIPES" can be assigned to a brew switch. Only one recipe per brew switch is allowed.

Procedure to select switch recipes

1. Press and hold the right hidden switch until the display reads **SET LANGUAGE**. Press the right hidden switch until the display reads **ASSIGN RECIPE?** Press **YES**.
2. The display should now read **SELECT RECIPE BREW SWITCH A**, and then **REGULAR (ICB) or TEA 1 (ITCB)**.
3. Using **(-)** and **(+)**, scroll through the stored recipes in the brewer's memory until the desired recipe name is reached.
4. Select **DONE** to set that recipe for brew switch A.
5. The display should now read **SELECT RECIPE BREW SWITCH B**, and then **DECAF (ICB) or HOT TEA (ITCB)**.
6. Using **(-)** and **(+)**, scroll through the stored recipes in the brewer's memory until the desired recipe name is reached.
7. Select **DONE** to set that recipe for brew switch B.
8. The display should now read **SELECT RECIPE BREW SWITCH C**, and then **BREAKFAST BLEND (ICB) or NO NAME COFFEE (ITCB)**.
9. Using **(-)** and **(+)**, scroll through the stored recipes in the brewer's memory until the desired recipe name is reached.
10. Select **DONE** to set that recipe for brew switch C.
11. Repeat steps 2 - 10 for right side of Twins.

Procedure to disable a Brew Switch:

1. Follow the same procedure as above. Choose **DISABLED** instead of recipe name.
2. Select **DONE** to disable that brew switch.

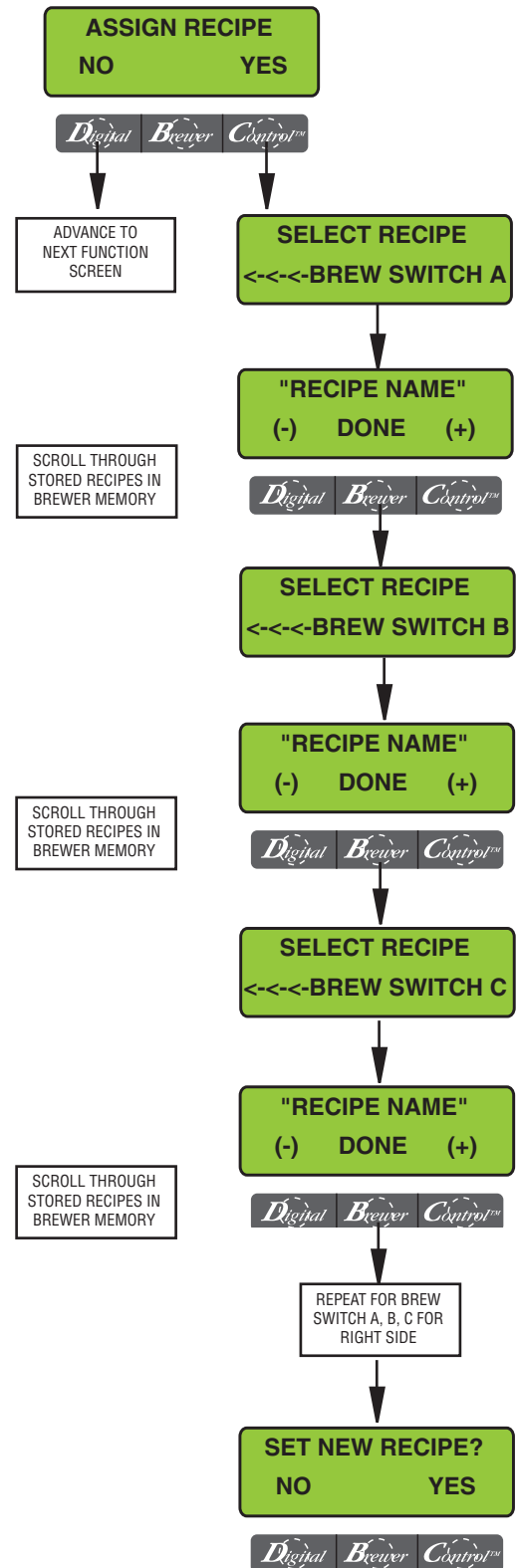

*** SET NEW RECIPE (COFFEE ONLY)**

To set a new COFFEE recipe using a Smart Funnel and a G9-2T DBC or MHG Grinder:

This function allows the operator to set BREW VOLUMES, BYPASS %, PULSE BREW/PREINFUSION TIMES AND DRIP OUT TIMES for each coffee name stored in the grinder's memory.

Certain coffee names are stored in the grinder's memory. When a particular name of coffee is ground into the Smart Funnel, that name and the batch size selected are transferred from the grinder to the programming CHIP located in the funnel handle. The funnel is then inserted into the brewer's funnel rails. The SENSING COIL on the brewer reads the information contained in the handle. The name of the coffee flavor will then appear on the display. This allows the operator to set the BREW VOLUMES, BYPASS % (N/A on ITCB), PULSE BREW/PREINFUSION TIMES AND DRIP OUT TIMES for that particular coffee name. Each coffee name can be set individually to provide optimum brewing quality.

SET NEW COFFEE ITEMS		
ICB	ITB/ITCB	ITCB HV
Brew Ounces		
% Bypass	Dilution Oz	Both
	Dilution Delay Time	
Pulse Brew/Preinfusion Times		
Drip Times		
	* SWEET METER	

*** MODELS WITH FACTORY SWEETENER**

Procedure for Setting the Recipe:

NOTE: Before beginning setup, place a server beneath the brew funnel.

1. Insert the funnel into the grinder and select the small batch size to grind. It is not necessary to have coffee beans in the hopper(s) in order to program the brewer. The coffee name is pre-selected and stored in the grinder's memory for the side being ground.
2. Press the GRIND switch. When the grinder stops grinding, remove the funnel.
3. On the brewer, press and hold the right hidden

switch until the display reads SET LANGUAGE. Press and release the right hidden switch until the display reads SET NEW RECIPE.

4. Select YES. The display should read INSERT FUNNEL WITH NEW NAME, then QUIT SETUP? These two displays will repeatedly cycle.
5. Insert the funnel into the rails on the brewer (Left on Twins). The display should read the name of the coffee that was ground into the funnel, along with a NO and YES. If the name on the display is correct, press YES.
6. If, for some reason, the name of the coffee from the grinder did not load properly into the funnel, or if a grind has not yet been done, the display will read MUST GRIND INTO FUNNEL FIRST. It will be necessary to grind another batch following steps 1, 2 & 5.

NOTE: If brewer memory is full, the display will read RECIPE STORAGE AREA IS FULL and then REMOVE A FLAVOR? To remove a recipe press and release YES. Press NEXT to scroll through the stored recipes. When the display reads the name of the recipe to be removed, press and release REMOVE. The display will read REMOVE? Press CANCEL to exit the SET NEW RECIPE function. Press OK to remove that recipe. The display will then show BEGIN SETUP OF (COFFEE NAME).

7. If the grind is acknowledged by the brewer, the display will read BEGIN SETUP OF (COFFEE NAME). Then the screen will display BREW OZ and a batch light will be blinking. Follow steps on page 11 (Review Recipes) to adjust recipe settings.

PROGRAMMING THE BREWER (cont.)

PROGRAMMING FUNCTIONS - LEVEL 2 (cont.)

* SET TEMP - ICB (MASTER TEMP - ITCB/HV)

This function allows the operator to adjust the brew water temperature in the tank. This also sets the hot water faucet dispense temperature.

Procedure for setting the Set Temp

Range: 185° to 205° F (85° - 96° C)

1. Press and hold the right hidden button until the display reads **SET LANGUAGE**. Press the right hidden button until the display reads **SET TEMP**.
2. Using (-) and (+), adjust the brew and faucet temperature.
3. When finished, press and release **DONE** to save the new setting and to advance to the next function screen, **READY DEGREE**. Press **ENABLE BREW ON/OFF** switch to exit programming and return to the **MAIN SCREEN**.

* READY DEGREE

This function allows the operator to set the minimum temperature allowable to start a brew cycle. The range can be from 2° to 20° F below the set temperature. The water must be at the **READY** temperature or higher for the display to indicate **READY TO BREW**. If brew lockout is enabled, the brewing process will not start below this **READY** temperature.

Procedure to set ready temperature

Range: 2° to 20° F (2° to 10° C) below set temp

1. Press and hold the right hidden button until the display reads **SET LANGUAGE**. Press the right hidden button until the display reads **READY DEGREE**.
2. Using (-) and (+), adjust the ready temperature.
3. When finished, select **DONE** to save the new setting and to advance to the next screen, **ENABLE ADS**. Press **ENABLE BREW ON/OFF** switch to exit.

* ENABLE ADS

This function allows the operator to choose whether or not to display an advertising message. An ad can be saved to the brewer by either writing the ad using the programming commands, or by entering the ad into the brewer using an **AD CARD**. This message will be displayed when the brewer is not in use.

Procedure to Enable/Disable Ads:

1. Press and hold the right hidden button until the display reads **SET LANGUAGE**. Press the right hidden button until the display reads **ENABLE ADS**. The **YES** or **NO** will be flashing to indicate the current selection.
2. Select **NO** to disable this function, or:
3. Select **YES** to enable this function.
4. When finished, select **DONE** to save the new setting and advance to the next function screen.
5. If **NO** was selected, the display should now read **ENABLE SANITATION**. To exit programming and return to the **MAIN SCREEN**, press **ENABLE BREW ON/OFF** switch.
6. If **YES** was selected, the display should now read **NEW AD?**. This screen allows the operator to select between using an ad card to *read* in a new ad, or *writing* an ad through the control panel.

Procedure to WRITE an Ad:

NOTE: Writing and saving a new ad will erase any previously saved ad in the brewer's memory.

7. From the **NEW AD?** screen, select **WRITE**.
8. The display should now read **2 LINES 16 CHARS AVAILABLE**, and then **SCROL THRU ALPHA, NEXT -> NEXT LETTER**, and then **WRITE TOP LINE?**. The ad can be up to 32 characters long, 16 per line. The ad will be written in two steps, first the top line, then the bottom line.
9. To write the top line of a new ad, select **YES**. To skip the top line and only write a bottom line, select **NO** and proceed to step 13.
10. The display will now read **A** with a flashing cursor below it. Press the **SCROLL** button to scroll through the alphabet and available characters. When the desired character is shown on the display, select **NEXT** to move to the next character in the top line.
11. Repeat step 10 until the top line is complete.

PROGRAMMING THE BREWER (cont.)

PROGRAMMING FUNCTIONS - LEVEL 2 (cont.)

12. Select **DONE**. The display should now read **WRITE BTM LINE?**
13. To write the bottom line, select **YES**.
14. To skip the bottom line, select **NO**.
 - a. If neither a top nor bottom line was written, the display should now read **ENABL SANITATION**.
 - b. If only a top line was written, the ad will be displayed followed by **SAVE?** Proceed to step 18.
15. The display will now read **A** with a flashing cursor below it. Scroll through the alphabet and available characters. When the desired character is shown on the display, select **NEXT** to move to the next character in the bottom line.
16. Repeat step 15 until the bottom line is complete.
17. Select **DONE**. The display will now show the written ad, and then **SAVE?**
18. To cancel saving the ad, select **NO**. The display should now read **ADVERTISEMENT NOT SAVED!** and then will return to the **NEW AD** screen.
19. To correct or edit the ad, select **EDIT**. The display should now read **WRITE TOP LINE?** Repeat steps 10 through 17.
20. To save the ad as it is shown, select **YES**. The display should now read **ADVERTISEMENT SETUP COMPLETE**, and then **ENABL SANITATION**. To exit programming and return to the **MAIN SCREEN**, press **ENABLE BREW ON/OFF** switch.

Procedure to READ in a new Ad: Not available on ITB
NOTE: Saving a new ad will erase any previously saved ad in the brewer's memory.

7. From the **NEW AD?** screen, select **CARD**.
8. The display will show **INSERT AD CARD**. Place the AD CARD vertically so that the top end of the "chip" is beneath the sensing coil (located on the underneath side of the front display panel).
9. After a short pause, the display will read **CARD CONTAINS AD**. To view the ad, press and release **SHOW**. To save the ad to the brewer's memory, select **SAVE**. To cancel, select **QUIT**.
10. After the ad is saved, the display will read **AD MESSAGE SETUP COMPLETE**, and then will advance to **ENABLE SANITATION**.

* **ENABLE SANITATION**

This function allows the operator to enable the sanitation function and set the time before a cleaning alert will be displayed.

Procedure for enabling sanitation:

Range: 0.0 to 72.0 hrs

1. Press and hold the right hidden button until the display reads **SET LANGUAGE**. Press and release the right hidden button until the display reads **ENABL SANITATION**. The **YES** or **NO** will be flashing to indicate the current selection.
2. Select **NO** to disable this function (no sanitation alert will be displayed on the screen), or:
3. Select **YES** to enable this function (a sanitation alert will be displayed on the screen).
4. When finished, select **DONE** to save the new setting and advance to the next function screen.
5. If **NO** was selected, the display should now read **ENABLE ENERGYSAVR**. To exit programming and return to the **MAIN SCREEN**, press **ENABLE BREW ON/OFF** switch.
6. If **YES** was selected, the display should now read **X.X HRS -> CLEAN**. This screen allows the operator to set the amount of time from when a brew is completed until a sanitize alert will be displayed. Use **(-)** and **(+)** to adjust the set time. When finished, select **DONE**.

NOTE: The timer will not begin until after a brew cycle has been completed.

7. The display should now read **X.X HRS UNTIL NEXT CLEAN**, and then advance to **ENABLE ENERGYSAVR**.
8. Once the set time has expired, the display will read **PLEASE SANITIZE**, and then **PRESS FULL FOR 3 SEC TO CANCEL**.
9. Clean and sanitize the machine.
10. When finished, press and hold the FULL batch switch to reset the Sanitation timer. The display should now read **SANITATION COMPLETE** and then will return to the **MAIN SCREEN**.

* **ENABLE ENERGY SAVER**

This function allows the operator to enable the ENERGY

PROGRAMMING THE BREWER (cont.)

PROGRAMMING FUNCTIONS - LEVEL 2 (cont.)

SAVINGS mode function and set the idle time. Once the set idle time has expired, the operator can choose to have the heaters either turn off, or reduce the tank holding temp to 140° F (60° C).

Procedure to enable energy savings mode:

Range: 0.5 to 24.0 hrs

If enabled, default setting is 140° F (60° C) tank temperature after 4.0 hrs. idle time.

1. Press and hold the right hidden switch until the display reads **SET LANGUAGE**. Press and release the right hidden switch until the display reads **ENABLE ENERGYSAVR**. The **YES** or **NO** will be flashing to indicate the current selection.
2. Select **NO** to disable or:
3. Select **YES** to enable this function.
4. When finished, press and release **DONE** to save the new setting and advance to the next screen.
5. If **NO** was selected, the display should now read **EnableFreshTimer**. To exit programming and return to the **MAIN SCREEN**, press **ENABLE BREW ON/OFF** switch.
6. If **YES** was selected, the display should now read **X.X HRS -> IDLE**. This screen allows the operator to set the amount of time the brewer is not in use before energy save mode engages. Using (-) and (+), adjust the idle time. When finished, select **DONE**.
7. The display should now read **AFTER IDLE TIME?** Once the set idle time has expired, the heaters can either be shut off or held at 140° F.
8. To have the heaters shut off after the set idle time, select **OFF** and then **DONE** to save the settings. The display should read **MACHINE OFF AFTER X.X HRS**, and then **EnableFreshTimer**.
9. To have the temperature reduce to 140° F, select **140°** and then **DONE** to save the settings. The display should read **MACHINE AT 140° AFTER X.X HRS**, and then **EnableFreshTimer**.
10. Once the idle time has expired, the display will read either **ENERGY SAVER...NO TEMPERATURE** or **ENERGY SAVER...REDUCED TEMPERATURE**, depending on the settings. This screen will alternate with **PRESS ANY SWITCH TO RE-HEAT**.

* **ENABLE FRESH TIMER**

This function allows the operator to enable the Fresh-

ness Alert and set the expiration time. The expiration time is the amount of time the product is allowed to sit in the server/dispenser before a fresh batch is brewed.

Procedure for enabling/setting the Freshness Timer:

Range: Coffee 0.5 to 4.0 hrs

Hot Tea 0.5 to 8.0 hrs

If enabled, default setting is 2.0 hrs. for Coffee and 2.0 hrs. for Hot Tea.

1. Press and hold the right hidden button until the display reads **SET LANGUAGE**. Press and release the right hidden button until the display reads **ENABLE FRESHTIMER**.
2. Select **NO** to disable or:
3. Select **YES** to enable this function (the unit will display a message once the set time has expired).
4. When finished, select **DONE** to save the new setting and advance to the next screen.
5. If **NO** was selected, the display should now read **REFILL**. To exit programming and return to the **MAIN SCREEN**, press either **ENABLE BREW ON/OFF** switch.
6. If **YES** was selected, the display should now read **COFFEE**. This screen allows the operator to set the amount of time from the end of brewing a batch of coffee until a Freshness Alert message will be displayed. Using (-) and (+), adjust the freshness time for coffee. When finished, select **DONE**.
7. The display should now read **HOT TEA**. Using (-) and (+), adjust the freshness time for hot tea. When finished, select **DONE**.
8. This display should now read **REFILL**. To exit programming and return to the **MAIN SCREEN**, press **ENABLE BREW ON/OFF** switch.
9. Once the set time has expired, the display will read **FRESHNESS ALERT BREW (A,B or C)**, and then **FRESHNESS ALERT BREW FRESH BATCH** alternating with the **MAIN SCREEN**.
10. Empty the server/dispenser the previous batch was brewed into and replace under the funnel.
11. Brew a new batch
12. The freshness timer will reset. The display should now return to the **MAIN SCREEN**.

* **REFILL**

Range: 0 to 155

PROGRAMMING THE BREWER (cont.)

PROGRAMMING FUNCTIONS - LEVEL 2 (cont.)

This function allows the operator to adjust the sensitivity of the refill circuit. This is mainly a troubleshooting feature. Water in different geographical locations can have different conductivities. By adjusting the sensitivity of the refill circuit, this will allow the brewer to operate under various water conditions.

Procedure to set the sensitivity threshold of the refill circuit:

NOTE: Make sure the water in the tank is touching the refill probe.

1. Press and hold the right hidden switch until the display reads **SET LANGUAGE**. Press and release the right hidden switch until the display reads **REFILL** and shows a number on both sides of the word.
2. To adjust the threshold setting, press **(-)** to decrease or **(+)** to increase the setting.

NOTE: Always make sure that the number on the right is larger than the number on the left when water is in contact with the refill probe in the tank.

3. When finished, select **DONE**. This saves the new setting and advances to the next function screen **(L) SPRAY OZ/M**. To exit programming and return to the **MAIN SCREEN**, press **ENABLE BREW ON/OFF** switch.

* **SPRAY OZ/M**

This function allows the operator to view or enter the actual flow rate coming out of each sprayhead. This is **NOT** used to control the actual flow rate, but to tell the internal processor how fast the water is flowing.

Procedure to set the sprayhead flow rate:

1. Press and hold the right hidden switch until the display reads **SET LANGUAGE**. Press and release the right hidden switch until the display reads **SPRY OZ/M**. The number represents what the brewer thinks is the flow rate out of that sprayhead.
2. If the actual flow rate of the sprayhead is known but is different than the number on the display, use the **(-)** and **(+)** to enter the correct flow rate.
3. Select **DONE**.
4. Repeat procedure for right side of Twins.
5. When finished, press and release **DONE** to advance

to the next screen. To exit programming and return to the **MAIN SCREEN**, press **ENABLE BREW ON/OFF** switch.

NOTE: If the flow rate is unknown, proceed to the **CALIBRATE FLOW** screen.

* **BYPASS OZ/M (ICB/ITCB HV/Twins only)**

This function allows the operator to view or enter the actual flow rate coming out of each bypass fitting. This is **NOT** used to control the actual flow rate, but to tell the internal processor how fast the water is flowing.

Procedure to adjust the bypass flow rate setting:

1. Press and hold the right hidden switch until the display reads **SET LANGUAGE**. Press and release the right hidden switch until the display reads **BYPASS OZ/M**. The number represents what the brewer thinks is the flow rate out of that bypass.
2. If the actual flow rate of the bypass is known but is different than the number on the display, use the **(-)** and **(+)** to enter the correct flow rate.
3. Select **DONE**.
4. Repeat procedure for right side of Twins.
5. When finished, press and release **DONE** to advance to the next screen. To exit programming and return to the **MAIN SCREEN**, press **ENABLE BREW ON/OFF** switch.

NOTE: If the flow rate is unknown, proceed to the **CALIBRATE FLOW** screen.

* **DILUTE OZ/M (ITB/ITCB/HV only)**

This function allows the operator to view or to enter the actual flow rate coming out of the dilution nozzle. This is **NOT** used to control the actual flow rate, but to tell the internal processor how fast the water is flowing.

Procedure to adjust the dilution flow rate setting:

1. Press and hold the right hidden switch until the display reads **SET LANGUAGE**. Press and release the right hidden switch until the display reads **DILUTE OZ/M**. The number represents what the brewer thinks is the flow rate out of the dilution nozzle.
2. If the actual flow rate of the nozzle is known but is different than the number on the display, use the **(-)** and **(+)** to enter the correct flow rate.

PROGRAMMING THE BREWER (cont.)

PROGRAMMING FUNCTIONS - LEVEL 2 (cont.)

- When finished, select **DONE**. This saves the new setting and advances to the next screen, **CALIBRATE FLOW**. To exit programming and return to the **MAIN SCREEN**, press **ENABLE BREW ON/OFF** switch.

NOTE: If the flow rate is unknown, proceed to the **CALIBRATE FLOW** screen.

* CALIBRATE FLOW

This function allows the operator to test and enter the actual flow rate of the sprayhead(s) and the bypass/dilution for each side of the brewer by dispensing each separately for one minute. The volumes are then entered into the brewer.

Procedure to calibrate the sprayhead flow rate:

- Place a container, accurately graduated with a minimum capacity of 60 ounces, under the funnel.
- Press and hold the right hidden switch until the display reads **SET LANGUAGE**. Press and release the right hidden switch until the display reads **CALIBRATE FLOW?**
- Select **YES** to advance to **SPRAY HEAD CAL** screen. (Selecting **NO** in the **CALIBRATE FLOW** screen will advance to **BREW COUNTERS**).
- Select **YES**.
The display should read **CONTAINER READY?** If container is under the funnel, select **YES**.
- The display should read **CALIBRATE SPRAY**. Press and release any **BREW** button on the side to be calibrated to begin the sprayhead flow for calibration. The display should read **CALIBRATE SPRAY...60 SEC TO FINISH**. The 60-second timer on the display will count down to zero. When the counter reaches zero, the display will change to **LEFT or RIGHT OZ**, along with a number.
- Measure the amount of water in the container and use **(-)** and **(+)** to match the display to the amount in the container. Then select **DONE**.
- The display should now read **NEW L or NEW R SPRY FLOW**, along with the correct flow rate of the sprayhead. After about 5 seconds, the display will return to the **CALIBRATE FLOW** screen.
- Repeat steps 1-7 to calibrate the other side.
- To exit the **CALIBRATE FLOW** function and advance to the next screen, select **NO**. To exit programming

and return to the **MAIN SCREEN**, press either **ENABLE BREW ON/OFF** switch.

Procedure to calibrate the bypass flow rate: (ICB/HV)

- Place a container, accurately graduated with a minimum capacity of 60 ounces, under the funnel.
- Press and hold the right hidden switch until the display reads **SET LANGUAGE**. Press and release the right hidden switch until the display reads **CALIBRATE FLOW?**
- Select **YES** to advance to **SPRAY HEAD CAL** screen. Select **NO** to advance to **BYPASS CAL**.
- Select **YES**.
The display should read **CONTAINER READY?** If container is under the funnel, select **YES**.
- The display should read **CALIBRATE BYPASS**. Press any **BREW** button on the side to be calibrated to begin the flow for calibration. The display should read **CALIBRATE BYPASS...60 SEC TO FINISH**. The 60-second timer on the display will count down to zero. When the counter reaches zero, the display will change to **LEFT or RIGHT OZ/M**, along with a number.
- Measure the amount of water in the container and using the **(-)** and **(+)**, adjust the amount on the display to match the amount in the container. Then select **DONE**.
- The display should now read **NEW L or NEW R BYPS FLOW**, along with the correct flow rate of the bypass. After about 5 seconds, the display will return to the **CALIBRATE FLOW** screen.
- Repeat steps 1-7 to calibrate the other side.
- To exit the **CALIBRATE FLOW** function and advance to the next function screen, select **NO**. To exit programming and return to the **MAIN SCREEN**, press **ENABLE BREW ON/OFF** switch.

Procedure to calibrate the dilution flow rate: ITB/ITCB

- Place a container, accurately graduated with a minimum capacity of 130 ounces, under the funnel.
NOTE: If the display is already on the **DILUTION CAL** screen, skip steps 2-3 and proceed directly to step 4.
- Press and hold the right hidden switch until the

(cont. on page 24)

PROGRAMMING THE BREWER (cont.)

PROGRAMMING FUNCTIONS - LEVEL 2 (cont.)

* CALIBRATE FLOW (cont.)

ALL ICB/ITCB HV

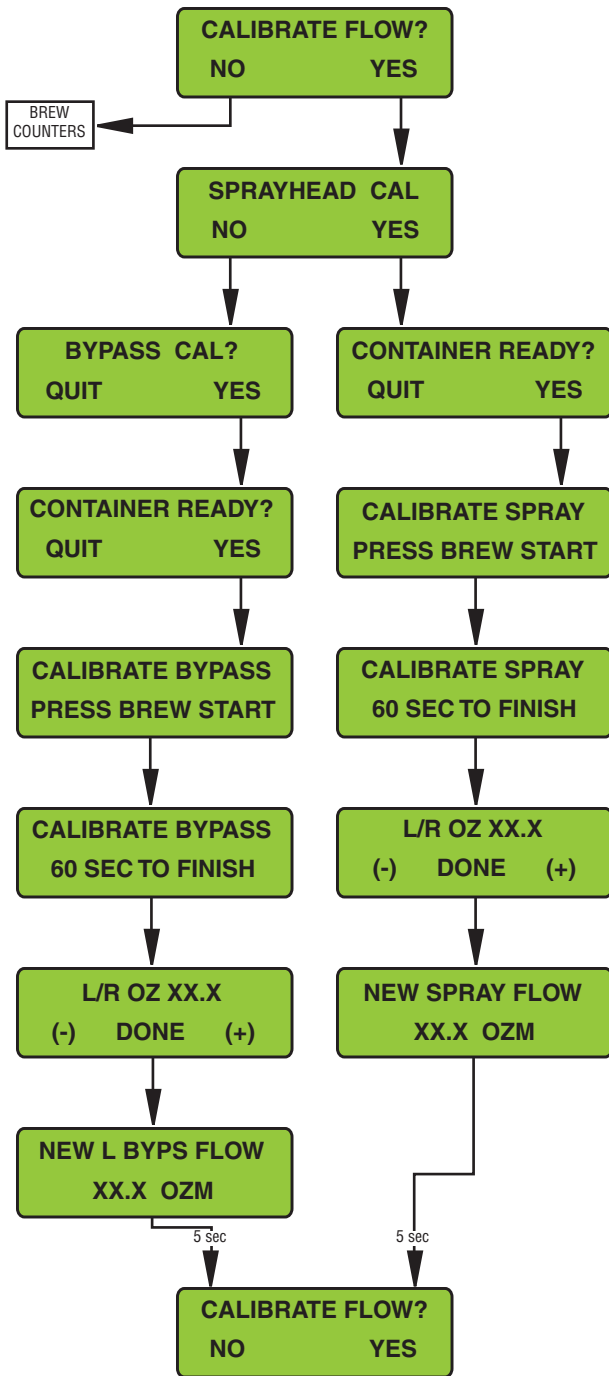

ALL ITB/ITCB/HV



PROGRAMMING THE BREWER (cont.)

PROGRAMMING FUNCTIONS - LEVEL 2 (cont.)

display reads **SET LANGUAGE**. Press and release the right hidden switch until the display reads **CALIBRATE FLOW?**

3. Select **YES** to advance to **SPRAY HEAD CAL** screen. Select **NO** to advance to **DILUTION CAL**.
4. Select **YES**.
The display should read **CONTAINER READY?** If container is under the funnel, select **YES**.
5. The display should read **CALIBRATE DILUTE**. Select **START** to begin the dilution flow for calibration. The display should read **CALIBRATE DILUTE...60 SEC TO FINISH**. The 60-second timer on the display will count down to zero. When the counter reaches zero, the display will change to **DILUTE OZ/M**, along with a number.
6. Measure the amount of water in the container and using the **(-)** and **(+)**, adjust the amount on the display to match the amount in the container. Then select **DONE**.
7. The display should now read **NEW DILUTE FLOW**, along with the correct flow rate of the sprayhead. After about 5 seconds, the display will return to the **CALIBRATE FLOW** screen. To exit programming and return to the **MAIN SCREEN**, press **ENABLE BREW ON/OFF** switch.

NOTE: On dual dilution models, left and right dilution calibrations will be shown.

PROGRAMMING THE BREWER (cont.)

PROGRAMMING FUNCTIONS - LEVEL 2 (cont.)

* BREW COUNTERS

This function allows the operator to track the total number of brew cycles completed, as well as the number of batches brewed using each of the brew buttons. There are (up to) six resettable counters, and one life counter that is not resettable.

Procedure to view/reset the brew counters:

1. Press and hold the right hidden switch until the display reads **SET LANGUAGE**. Press and release the right hidden switch until the display reads **BREW COUNTERS**.
2. Pressing **NO** will advance to the next programming function. Select **YES** to view the first brew counter (**TOTAL LIFE BREWS**). This number represents the total number of brew cycles this brewer has completed. This counter is non-resettable. Press **NEXT** to advance to the next brew counter, <- <- **BREW A** (left side).
3. This counter represents the number of brews for Brew A on the left side of the brewer. To reset the counter to zero, press and release **RESET**. Press and release **NEXT** to advance to the next counter.
4. Repeat step 3 for the remaining two left counters, **BREW B** and **BREW C**.
5. Repeat step 4 for the three right side brew counters. (Twin only)
6. When finished, press **NEXT** to advance to the next programming function, **ENTER ASSET #**. To exit programming and return to the **MAIN SCREEN**, press **ENABLE BREW ON/OFF** switch.

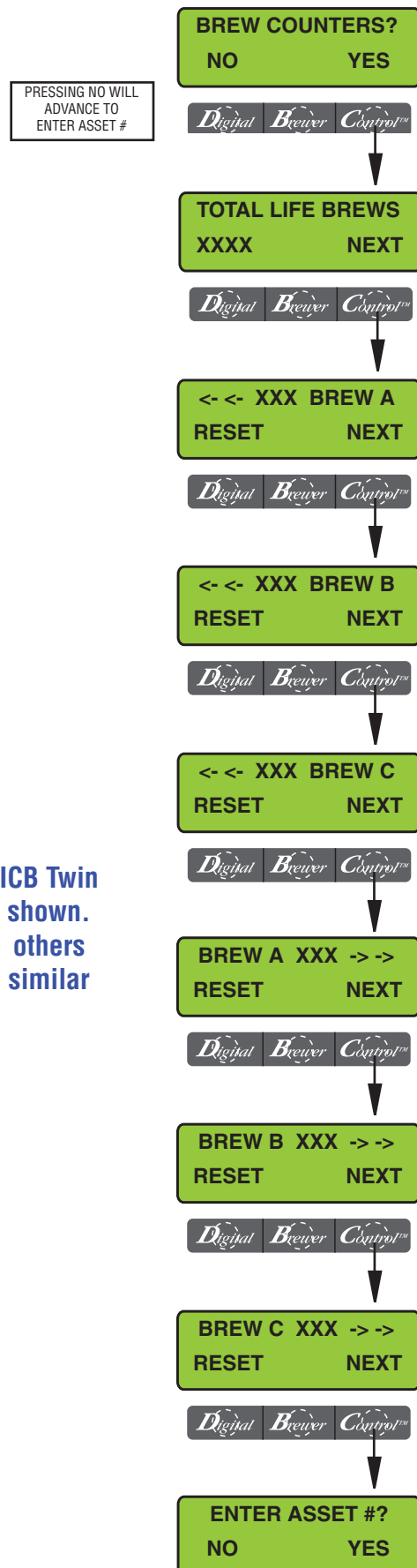

PROGRAMMING THE BREWER (cont.)

PROGRAMMING FUNCTIONS - LEVEL 2 (cont.)

* SET RECIPE TEMPS (ITCB only)

This function allows the operator to set separate temperatures for each selected recipe.

NOTE: Setting recipe temps will override the MASTER TEMP. The tank will hold at the lowest temperature between the three selected recipes stored in the brew buttons. For instance, let's say Brew A's recipe temperature is set at 205°, Brew B's recipe temperature is set at 205°, and Brew C's recipe temperature is set at 200°. The tank will hold at 200°. If Brew A or Brew B is pressed, the tank will heat to the 205° temperature. The brew button must be pressed again in order for a brew to start. After the completion of that brew, the tank will return to the 200° holding temperature. It may take awhile for the tank to return to the lower temperature.

1. Press and hold the right hidden switch until the display reads **SET LANGUAGE**. Press and release the right hidden switch until the display reads **SET RECIPE TEMPS**.
2. To set different temperatures for different recipes, press and release **YES**. Pressing **NO** will advance to the next programming function, **SERVICE TOOLS**.
3. The display should read **WILL OVERRIDE THE MASTER TEMP**, and then **OVERRIDE?** To retain the **MASTER TEMP** setting, press and release **NO**. To set separate recipe temperatures, press and release **YES**.
4. The display should read **TEA 1**. Using **(-)** and **(+)**, adjust the temperature for **TEA 1**. When finished, press and release **DONE**.
5. The screen should now read **TEA 2**. Use **(-)** and **(+)** to adjust the temperature for **TEA 2**. When finished, press and release **DONE**.
6. Repeat for all standard and stored recipes.
7. After the last temperature has been entered, press **DONE**. The screen should now read **TANK WILL HOLD AT LOWEST TEMP**, and then advance to the **ENTER ASSET #** screen. To exit programming and return to the **MAIN SCREEN**, press **ENABLE BREW ON/OFF** switch.

NOTE: To return to using the **MASTER TEMP** setting after **RECIPE TEMPS** have been used, press and hold

the right hidden switch until the display reads **SET LANGUAGE**. Press and release the right hidden switch until the display reads **SET RECIPE TEMPS**. Select **YES**. The display will read **WILL OVERRIDE THE MASTER TEMP**, and then **OVERRIDE?** To return to using the **MASTER TEMP**, select **NO**. To exit programming and return to the **MAIN SCREEN**, press **ENABLE BREW ON/OFF** switch.

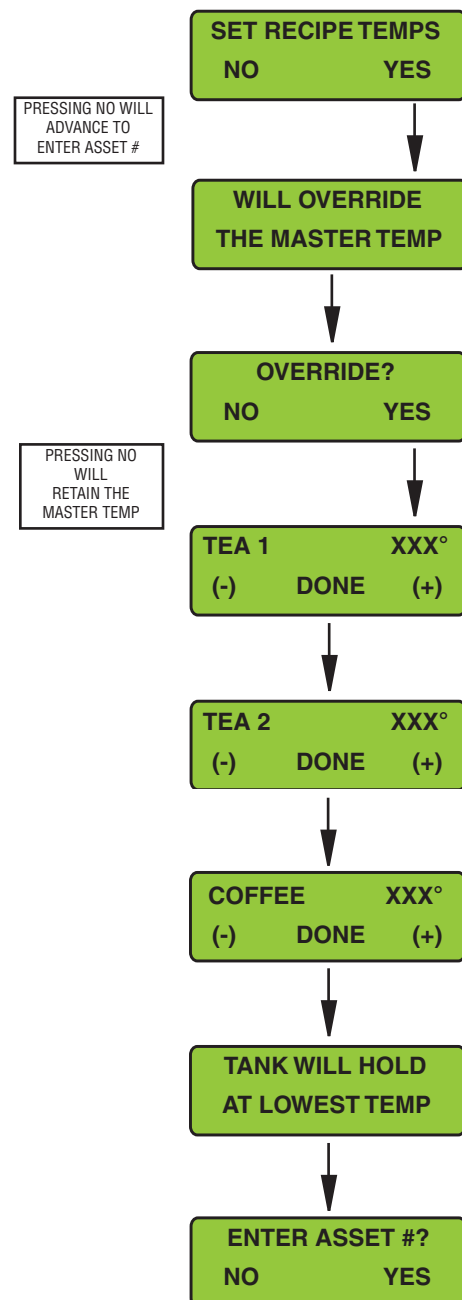

PROGRAMMING THE BREWER (cont.)

PROGRAMMING FUNCTIONS - LEVEL 2 (cont.)

* ASSET NUMBER

This function allows the operator to enter the machine's asset number. This can be useful for tracking the usage or service of an individual machine within a group.

Procedure to enter the asset number:

1. Press and hold the right hidden switch until the display reads **SET LANGUAGE**. Press and release the right hidden switch until the display reads **ENTER ASSET #?**
2. Select **YES**. The display will now read **ANXXXXXX**.
3. Scroll down (-) or up (+), to set the asset number of the machine. **NOTE:** Starting from the right, each digit will control the next digit, like an odometer.
4. When finished, press and release **DONE**. The display will now read **SERVICE #**. To exit programming and return to the **MAIN SCREEN**, press **ENABLE BREW ON/OFF** switch.

NOTE: To view the Asset Number, press and hold the left hidden switch until the display reads **ASSET NUMBER**. After releasing the switch, the display will read **SERIAL NUMBER** then the software version.

* SERVICE NUMBER

This function allows the operator to enter in the telephone number to call if service is needed. The service number will be displayed anytime there is a fault message displayed.

Procedure to enter the service number:

1. Press and hold the right hidden switch until the display reads **SET LANGUAGE**. Press and release the right hidden switch until the display reads **ENTER SERVICE #?**
2. Press and release **YES**. The display will now read **SCROL THRU #'S NEXT ->NEXT NUMBER**, followed by **000-000-0000**. UP TO 16 CHARACTERS ARE AVAILABLE.
3. Press the **SCROL** button to scroll through the numbers. When the desired number is shown, press and release **NEXT** to move to the next digit in the phone number.
4. Repeat Step 3 until the entire number is entered.
5. Press and release **DONE**. The display will now read **SERVICE TOOLS?**

* SERVICE TOOLS

(FOR AUTHORIZED SERVICE PERSONNEL ONLY)

This function allows the testing of individual components and the ability to check switches for proper function. This function also tests the funnel sensor coil's frequency (diagnostic tool for troubleshooting purposes only). Refer to Service Manual for in depth procedures.

Test Outputs:

The following components can be individually tested:

- (L/R) Brew Valve(s)
- (L/R) Bypass Valve(s) ITCB HV/ICB(TWIN)
- (L/R) Dilution Valve(s) ITB/ITCB/HV (w/Dual Dilution)
- Refill Valve
- Tank Heater Relay
- Tank Heater Triac
- L/R Funnel Lock (Optional)
- Sweetener Solenoid (Optional)

Test Switches:

The following components can be individually tested:

- Membrane Switches

Test Frequency: (NOT AVAILABLE ON ITB)

The following components can be individually tested:

- L/R Smart Funnel read coils.

* FACTORY DEFAULTS

This function allows the operator to erase **ALL** of the previously entered recipes and ad messages. Factory-set default values will replace **ALL** previous settings.

Procedure to set factory defaults:

1. Press and hold the right hidden switch until the display reads **SET LANGUAGE**. Press and release the right hidden switch until the display reads **FACTORY DEFAULTS**.
2. Press **YES** to restore defaults. The display will read **WILL REPLACE ALL BREW SETTINGS** followed with **ARE YOU SURE?**
3. Selecting **NO**, will exit without resetting. Select **YES** to load the defaults. After factory defaults have been restored, the display will return to the **MAIN SCREEN**. The factory default values will have replaced **ALL** previously entered values. It will NOT reset the life brew counter. If factory defaults are restored, it will be necessary to recalibrate the flow rates.

BREW ALERT (HIGH VOLUME MODELS ONLY)

When enabled, BREW ALERT causes the display to flash, indicating that a brew cycle is in process. BREW ALERT is disabled by default.

TROUBLESHOOTING

A troubleshooting guide is provided to suggest probable causes and remedies for the most likely problems encountered. If the problem remains after exhausting the troubleshooting steps, contact the Bunn-O-Matic Technical Service Department.

- Inspection, testing, and repair of electrical equipment should be performed only by qualified service personnel.
- All electronic components have 120-240 volt ac and low voltage dc potential on their terminals. Shorting of terminals or the application of external voltages may result in board failure.
- Intermittent operation of electronic circuit boards is unlikely. Board failure will normally be permanent. If an intermittent condition is encountered, the cause will likely be a switch contact or a loose connection at a terminal or crimp.
- Solenoid removal requires interrupting the water supply to the valve. Damage may result if solenoids are energized for more than ten minutes without a supply of water.
- The use of two wrenches is recommended whenever plumbing fittings are tightened or loosened. This will help to avoid twists and kinks in the tubing.
- Make certain that all plumbing connections are sealed and electrical connections tight and isolated.
- This brewer is heated at all times. Keep away from combustibles.

- WARNING** –
- **Exercise extreme caution when servicing electrical equipment.**
 - **Unplug the brewer when servicing, except when electrical tests are specified.**
 - **Follow recommended service procedures.**
 - **Replace all protective shields or safety notices.**

TROUBLESHOOTING (cont.)

PROBLEM	PROBABLE CAUSE	REMEDY
Temperature Too Low	1. Water temperature in the tank does not meet the ready temperature.	A) Wait for the brewer to heat to the proper temperature. B) Disable the BREW LOCKOUT function. See page 16 for procedure.
Heating Time Too Long	1. Tank Heater failure. 2. Control Board/Thermistor failure	Service required Service required
Fill Time Too Long	1. Water shut off to brewer 2. Inlet Solenoid failure 3. Control Board Failure 4. ON/OFF switch is OFF	Check water supply shut-off Service Required Service Required Turn switch ON
Temp Sensor Out Of Range, Check For Bad Connections	1. Temperature Sensor Probe wire(s) broken or not making connection	Check wire and connection of both black and white wires of temperature probe.
Temp Sensor Out Of Range, Check Wire For Shorts	1. Temperature Sensor Probe wire(s) shorted to housing or to each other.	Check to confirm that wire(s) are not pinched between two surfaces or connected to each other.
Equipment will not operate	1. No power or incorrect voltage	Measure the voltage at the terminal block and confirm that it matches the voltage specified on the brewer data plate withing +/- 10%.

TROUBLESHOOTING (cont.)

<u>PROBLEM</u>	<u>PROBABLE CAUSE</u>	<u>REMEDY</u>
Brew cycle will not start	1. No water	Check plumbing and shut-off valves
	2. No power or incorrect voltage to the brewer	Check for voltage across the terminals at the terminal block.
	3. ON/OFF switch	Test the ON/OFF switch. Refer to the test switch procedures on page 50.
	4. Brew switch	Test the BREW switch. Refer to the test switch procedures on page 50.
	5. Brew valve	Test the brew valve. Refer to the test outputs procedures on page 48.
	6. Control Board	Substitute a control board known to be in good working order. Check plumbing and shut-off valves
		Remove the strainer and check for obstructions. Clear or replace.

TROUBLESHOOTING (cont.)

<u>PROBLEM</u>	<u>PROBABLE CAUSE</u>	<u>REMEDY</u>
Automatic refill will not operate or display shows FILL TIME TOO LONG	<ol style="list-style-type: none">1. No water2. Refill probe or Sensitivity setting3. Refill valve	<p>Check the sensitivity setting. Refer to the REFILL function on page 40. If the left three digit number is less than the right number, the machine “thinks” it is full and the refill valve should be off. If the left number is larger than the right, then the refill valve will automatically be turned on to fill the tank. The right number is the threshold setting and can be adjusted to compensate for extreme water conditions: very pure, low conductance water requires a higher setting, while high mineral content, high conductance water requires a lower setting. Note that the left number changes from a high value when water is NOT touching the refill probe to a low value when water IS touching the probe. For best operation, the right number should be set to a value midway between these low and high numbers. Before changing the setting, confirm that the refill probe is free of scale buildup and the connection to it is secure. Test the refill valve. Refer to the test outputs procedures on page 48.</p> <p>Refill valve – Disconnect the brewer from the power source and remove wires from refill valve coil. Check for continuity across the terminals of the solenoid coil. If continuity is</p>

TROUBLESHOOTING (cont.)

<u>PROBLEM</u>	<u>PROBABLE CAUSE</u>	<u>REMEDY</u>
Automatic refill will not operate or display shows FILL TIME TOO LONG (Continued)		not present, replace the refill valve. If continuity is present, the coil may be stuck closed. Shut water off to brewer. Press the ON/OFF switch to turn off the brewer. Open the faucet and drain water down in the tank until flow stops or slows to a trickle. Attach a voltmeter to the terminals of the refill solenoid. Connect the brewer to the power source. Press the ON/OFF switch to turn the brewer on. Within five seconds, voltage should be present at the solenoid terminals. If voltage is not present, refer to the wiring schematic and check the wiring harness.
	4. Control Board	Substitute a control board known to be in good working order.
	5. ON/OFF Switch	ON/OFF switch must be ON for the refill circuit to operate. Turn ON.

TROUBLESHOOTING (cont.)

<u>PROBLEM</u>	<u>PROBABLE CAUSE</u>	<u>REMEDY</u>
Water flows into tank continuously with power removed from brewer.	1. Refill valve	Foreign material lodged in valve, holding it in open state.
	2. Refill probe or sensitivity setting	Check the sensitivity setting. Refer to the REFILL function on page 40. If the left three digit number is less than the right number, the machine “thinks” it is full and the refill valve should be off. If the left number is larger than the right, then the refill valve will automatically be turned on to fill the tank. The right number is the threshold setting and can be adjusted to compensate for extreme water conditions: very pure, low conductance water requires a higher setting, while high mineral content, high conductance water requires a lower setting. Note that the left number changes from a high value when water is NOT touching the refill probe to a low value when water IS touching the probe. For best operation, the right number should be set to a value midway between these low and high numbers. Before changing the setting, confirm that the refill probe is free of scale buildup and the connection to it is secure.
	3. Control Board	Substitute a control board known to be in good working order.

TROUBLESHOOTING (cont.)

<u>PROBLEM</u>	<u>PROBABLE CAUSE</u>	<u>REMEDY</u>
Water will not heat or display shows HEATING TIME TOO LONG.	1. Limit Thermostat	Remove power from the brewer. Check for continuity through the limit thermostat. CAUTION: Do not eliminate or bypass limit thermostat. Use only replacement part 29329.0001.
	2. Temperature probe	Remove the probe from the grommet and submerge in a water bath of approximately 70°F (21°C). Connect an ohmmeter to the pins in the connector. At 60°F (16°C), the reading should be 15.3k ± 2k OHMS, at 70°F (21°C) the reading should be 11.8k ± 2k OHMS, and at 80°F (27°C) the reading should be 9.3k ± 2k OHMS. If the probe is within these parameters, reconnect to the control board.
	3. Tank heaters	Remove power from the brewer. Check for continuity through the tank heaters. If no continuity is present, check for a wiring problem (consult wiring schematic), then replace the tank heater if no wiring problem is found.
	4. Control Board	Remove power from the brewer. Connect a voltmeter across the tank heater. Reapply power to the brewer and refer to testing outputs on page 48. If the voltage measured when the tank heater is turned on is very low or zero, then substitute a control board known to be good working order.

TROUBLESHOOTING (cont.)

<u>PROBLEM</u>	<u>PROBABLE CAUSE</u>	<u>REMEDY</u>
No bypass water	1. Bypass valve	Test the bypass valve. Refer to the test outputs procedures on page 48.
	2. Recipe settings 1. Lime buildup	Check to make sure bypass % has been set for the current recipe. Inspect the probe and tank assembly for excessive lime deposits. Delime as required.
Spitting or unusual steaming from sprayhead or air vent.	2. Temperature probe	Remove the probe from the grommet and submerge in a water bath of approximately 70°F (21°C). Connect an ohmmeter to the pins in the connector. At 60°F (16°C), the reading should be 15.3k ± 2k OHMS, at 70°F (21°C) the reading should be 11.8k ± 2k OHMS, and at 80°F (27°C) the reading should be 9.3k ± 2k OHMS. If the probe is within these parameters, reconnect to the control board.
	3. Control Board	Remove power from the brewer. Connect a voltmeter across the tank heater. Reapply power to the brewer and refer to testing outputs on page 48. If the voltage measured when the tank heater is turned on is very low or zero, then substitute a control board know to be good working order.

TROUBLESHOOTING (cont.)

<u>PROBLEM</u>	<u>PROBABLE CAUSE</u>	<u>REMEDY</u>
Inconsistent beverage level in server/dispenser	1. Improper water pressure	Check operating water pressure to the brewer. It must be between 20 and 90 psi (138 and 620 kPa).
	2. Brew valve	Test the brew valve. Refer to test outputs on page 48. Turn the valve on for 30 seconds and collect the water dispensed from the spray-head. Repeat the test several times to confirm a consistent volume of dispensed water. If not consistent, check the valve, tubing and spray-head for lime buildup.
	3. Bypass valve	If bypass is being used on the inconsistent brewing recipe, test the bypass valve. Refer to test outputs on page 48. Turn the valve on for 30 seconds and collect the water collected from the funnel. Repeat the test several times to confirm a consistent volume of dispensed water. If not consistent, check the valve, tubing and fittings for lime buildup.
	4. Lime buildup	Inspect for lime buildup that could block the tank, tank fittings, tubing, valves and sprayhead.
	5. Brew volume adjustment	Adjust the brew volume, calibrate sprayhead and bypass as required to achieve the desired volume for each brew cycle.

TROUBLESHOOTING (cont.)

<u>PROBLEM</u>	<u>PROBABLE CAUSE</u>	<u>REMEDY</u>
Dripping from sprayhead.	1. Brew valve	Repair or replace leaky valve
Water overflows filter.	1. Type of paper filter	BUNN paper filters should be used for proper extraction
	2. No sprayhead	Check sprayhead
Beverage overflows server.	1. Beverage left in server from previous brew	The brew cycle should be started only with an empty server under the funnel.
	2. Brew volume adjustment	Adjust the brew volume, calibrate sprayhead and bypass as required to achieve the desired volume for each brew cycle
Brewer is making unusual noises.	1. Solenoids	The mounting screws on the solenoids must be tight or they will vibrate during operation
	2. Plumbing lines	Plumbing lines should not be resting on the countertop.
	3. Water supply	The brewer must be connected to a cold water line. Water pressure to the brewer must not be higher than 90 psi (620 kPa). Install a regulator if necessary to lower the working pressure to approximately 50 psi (345 kPa).
	4. Tank heaters	Remove and clean lime off tank heaters.

TROUBLESHOOTING (cont.)

<u>PROBLEM</u>	<u>PROBABLE CAUSE</u>	<u>REMEDY</u>
Weak beverage.	1. Type of paper filter	BUNN paper filters should be used for proper extraction
	2. Coffee	For coffee, a sufficient quantity of fresh drip or regular grind should be used for proper extraction.
	3. Sprayhead	Bunn-O-Matic sprayhead should be used to properly wet the bed of ground coffee in the funnel
	4. Funnel Loading	The BUNN paper filter should be centered in the funnel and the bed of grounds leveled by gently shaking.
	5. Water temperature	Empty the server, remove its cover, and place the server beneath the sprayhead. Place empty funnel over the server entrance (not in the funnel rails). Press brew. Check the water temperature immediately below the sprayhead with a thermometer. The reading should not be less than 195°F (90°C).
	6. Incorrect recipe	Consider adjusting brew volumes, bypass percentage and pulse brew routines. Contact Bunn-O-Matic for suggestions.