



# ICB SH ICB SH TWIN

## Faucet Side Car Relocation Instructions

---

### TO BE PERFORMED BY QUALIFIED PERSONNEL

These instructions are intended for relocating the faucet side car on an ICB SH brewer. Ensure all tools are present before performing the installation.

**WARNING:** Disconnect the brewer from the power source before performing the procedure. Ensure the water is drained from the tank and be aware that many internal parts can be extremely hot; allow contents of tank to cool before proceeding.

Note: If technical assistance is needed, please call 1-800-286-6345

#### Tools Required:

8/32 socket/wrench  
Flat Blade Screwdriver



---

## BUNN-O-MATIC CORPORATION

POST OFFICE BOX 3227  
SPRINGFIELD, ILLINOIS 62708-3227  
PHONE: (217) 529-6601 FAX: (217) 529-6644

[www.bunn.com](http://www.bunn.com)

## ICB SH Faucet Side Car Installation Instructions

**STEP 1**

- Disconnect power to the brewer.
- Remove the screws that secure the front panel to the brewer (6 screws).

**STEP 2**

- Carefully remove the front panel of the brewer.

**STEP 3**

- Remove the three screws that secure the cover to the faucet side car.
- Remove the cover.

**STEP 4**

- Open the faucet handle to drain water from the tank. Keep the faucet handle open until water is no longer dispensing.
- Remove the hose snap clamp that secures the tube to the faucet shank.
- Carefully remove the hose from the faucet shank.

**STEP 5**

- Remove the two 8/32 nuts, two washers and base screw from the faucet side car.
- Remove the black silicone grommet.

**STEP 6**

- Completely remove the faucet side car, spacer and plate assembly from the left side of the brewer.

## ICB SH Faucet Side Car Installation Instructions

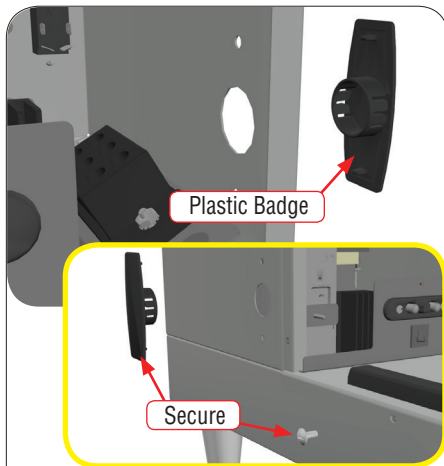

### STEP 7

- Remove the plastic badge from the right side of the brewer.
- Install the plastic badge on the left side of the brewer to cover the panel holes.
- Install the base screw that was removed in step 5.

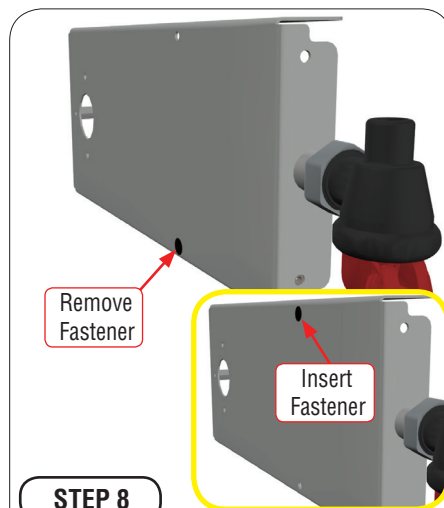

### STEP 8

- Remove the snap-in fastener from the faucet side car and place into the hole directly above as shown.

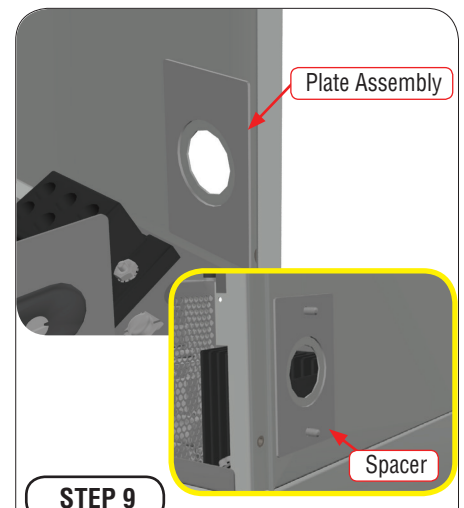

### STEP 9

- Place the plate assembly into the uncovered holes on the inside of the right panel.
- Place the spacer on the outside of the right panel on the plate assembly.

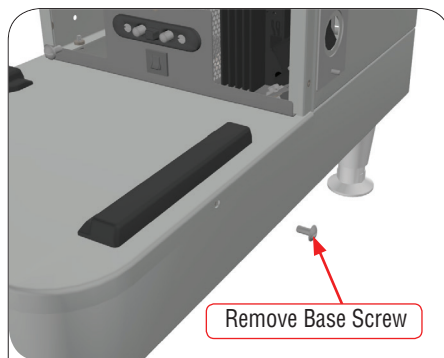

### STEP 10

- Remove the base screw on the right side.

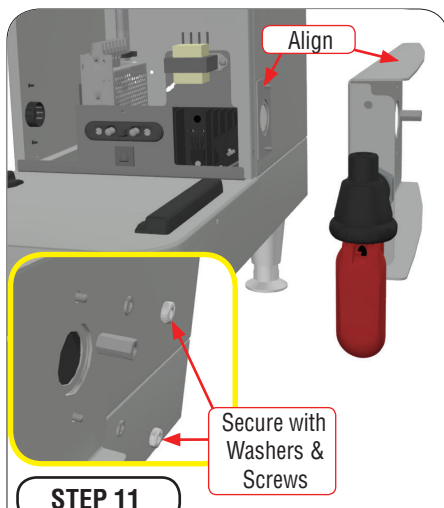

### STEP 11

- Align the faucet side car to the right side of the brewer.
- Secure the faucet side car using the washers and screws that were removed in step 5.

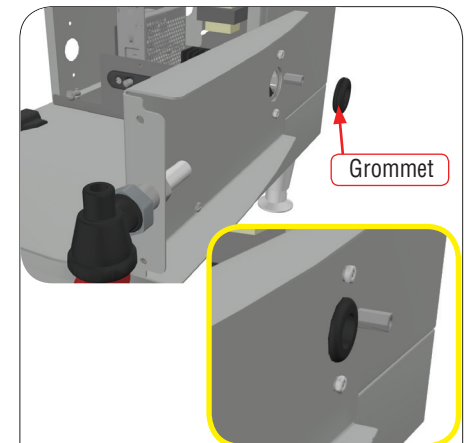

### STEP 12

- Insert the black grommet into the large tubing hole. This is the same grommet removed in step 5.
- Secure the base screw to the faucet side car.

## ICB SH Faucet Side Car Installation Instructions

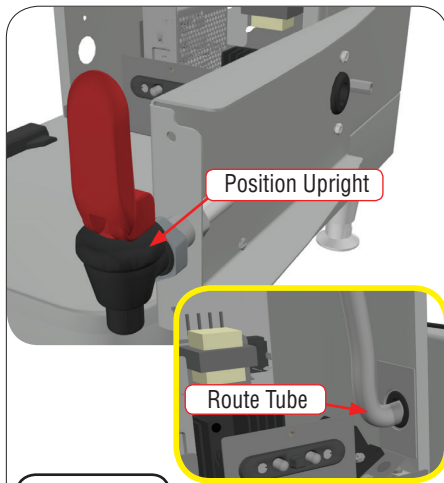

### STEP 13

- Loosen the faucet nut to rotate the faucet handle facing upwards.
- Route the faucet tube through the right side panel.
- Ensure there are no kinks in the tubing.

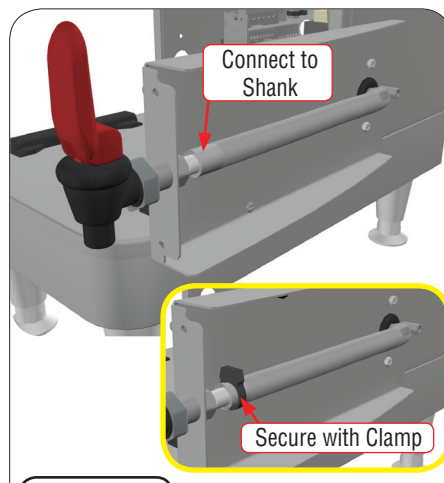

### STEP 14

- Attach the faucet tube to the faucet shank.
- Secure the tube to the shank using the hose snap that was removed in step 4.

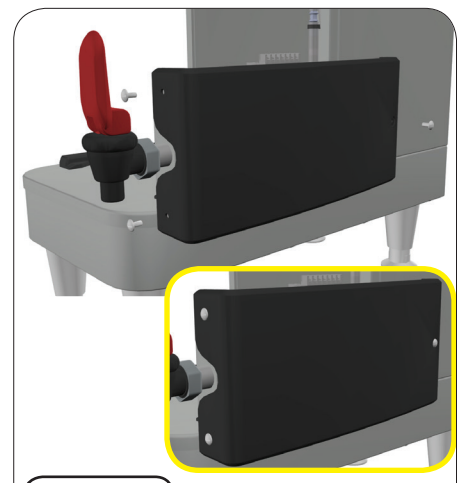

### STEP 15

- Secure the cover to the faucet side car using the screws that were removed in step 3.

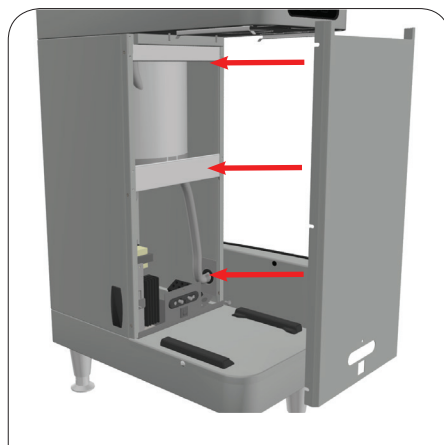

### STEP 16

- Place the front panel on the brewer.

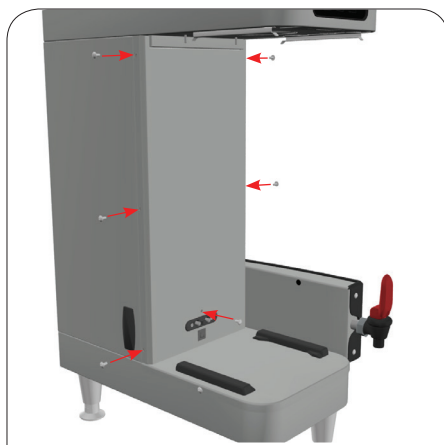

### STEP 17

- Secure the front panel to the brewer using the screws removed in step 1.



### STEP 18

- Faucet side car relocation is complete.